



HELPING OUR MEMBERS WORK TOGETHER
TO KEEP THE LIGHTS ON... TODAY AND IN THE FUTURE

September 21, 2016

The Honorable Kimberly D. Bose
Secretary
Federal Energy Regulatory Commission
888 First Street NE
Washington, DC 20426

Re: *Southwest Power Pool, Inc.*, Docket No. ER16-_____
Submission of Affected Systems' Facilities Construction Agreement

Dear Secretary Bose:

Pursuant to section 205 of the Federal Power Act, 16 U.S.C. § 824d, and section 35.13 of the Federal Energy Regulatory Commission's ("Commission") regulations, 18 C.F.R. § 35.13, Southwest Power Pool, Inc. ("SPP") submits an executed Affected Systems' Facilities Construction Agreement ("FCA") among SPP as Transmission Provider, AEM Wind LLC ("AEM") as Interconnection Customer, and Southwestern Public Service Company ("SPS") as Transmission Owner ("AEM FCA").¹ SPP requests an effective date of September 12, 2016, for the AEM FCA.

I. Description of SPP

SPP is a Commission-approved Regional Transmission Organization ("RTO"). SPP is an Arkansas non-profit corporation with its principal place of business in Little Rock, Arkansas. SPP has 94 members, including 16 investor-owned utilities, 14 municipal systems, 20 generation and transmission cooperatives, 8 state agencies, 13 independent power producers, 12 power marketers, and 10 independent transmission companies, and 1 federal agency. As an RTO, SPP is a transmission provider administering transmission service over portions of Arkansas, Iowa, Kansas, Louisiana, Minnesota, Missouri, Montana, Nebraska, New Mexico, North Dakota, Oklahoma, South Dakota, Texas and Wyoming. SPP is responsible for providing independent transmission services over the transmission facilities its members have placed under the SPP Open Access Transmission Tariff ("Tariff").² SPS has placed its transmission system under the functional control of SPP.

¹ A copy of the AEM FCA, designated as Original Service Agreement No. 3247, is included with this filing. In addition, SPP, AEM, and SPS are collectively referred to as "the Parties."

² See Southwest Power Pool, Inc., Open Access Transmission Tariff, Sixth Revised Volume No. 1.

The Honorable Kimberly D. Bose
September 21, 2016
Page 2

II. Background

AEM intends to own, and operate, or manage the AEM Interconnection Facilities relating to a 29.9 MW generating facility consisting of 13 G.E. 2.3 MW wind generators, located in Lea County, New Mexico with an expected commercial operation date of September 30, 2017, pursuant to a duly executed Interconnection Agreement (“IA”) with Lea County Electric Cooperative (“LCEC”) wherein the IA provides for interconnection service to interconnect the Generating Facility with the sub-transmission system of SPS, which system is interconnected to the SPS Transmission System, which is under SPP’s functional control.

In light of the interconnection of the Generating Facility to LCEC’s system, SPP performed a study to analyze the impact of the Generating Facility’s interconnection on the SPP transmission system. Based on the study, SPP determined that as a result of the interconnection of the Generating Facility to LCEC’s transmission system, transmission facilities are required on the SPS transmission system. While the IA governs the interconnection of the Generating Facility to LCEC’s transmission system, including specifying any upgrades required on that system, it does not address the upgrades needed on the SPS transmission system. Because SPS is an “Affected System,”³ it also is not a party to the IA (nor is SPP). Therefore, in order to memorialize the Parties’ responsibilities with regard to the construction of the upgrade on the SPS transmission system, SPP, AEM, and SPS entered into a FCA.⁴

Currently, SPP does not have a *pro forma* FCA in its Tariff. The Parties used SPP’s *pro forma* GIA⁵ and other Commission-accepted Facilities Construction Agreements as guidance in developing the AEM FCA. The *pro forma* GIA is an

³ An “Affected System” is “an electric system other than the Transmission System that may be affected by the proposed interconnection.” See Tariff at Attachment V, Section 1, Definitions.

⁴ See *Standardization of Generator Interconnection Agreements and Procedures*, Order No. 2003, 68 FR 49846 (Aug. 19, 2003), FERC Stats. & Regs. ¶ 31,146, at P 739 (2003), *order on reh’g*, Order No. 2003-A, 69 FR 15932 (Mar. 26, 2004), FERC Stats. & Regs., ¶ 31,160 (2004), *order on reh’g*, Order No. 2003-B, 70 FR 265 (Jan. 4, 2005), FERC Stats. & Regs., ¶ 31,171 (2005), *order on reh’g*, Order No. 2003-C, 70 FR 37661 (Jun. 30, 2005), FERC Stats. & Regs., ¶ 31,190 (2005), *aff’d sub nom. Nat’l Ass’n of Regulatory Utils. Comm’rs v. FERC*, 475 F.3d 1277 (D.C. Cir. 2007) (“When the Interconnection Customer is required to pay for Network Upgrades on an Affected System, it must enter into an agreement with the Affected System Operator unless the payments are incorporated in the interconnection agreement that the Interconnection Customer signs with the Transmission Provider.”).

⁵ See Tariff at Attachment V, Appendix 6 (hereinafter, the “*pro forma* GIA”).

The Honorable Kimberly D. Bose
 September 21, 2016
 Page 3

appropriate reference document for SPP's development of the FCA, because similar to a GIA, an FCA facilitates the construction of upgrades necessitated by the interconnection of a generating plant. However, because the upgrades are being constructed on an Affected System, some of the *pro forma* GIA provisions, in particular those regarding operations of the generating plant, are inapplicable and therefore were not included in the AEM FCA. Notably, the AEM FCA is similar and consistent with other Commission-accepted Facilities Construction Agreements filed by SPP⁶ and other transmission providers, pursuant to which interconnection customers are held responsible for the costs of upgrades on Affected Systems required as a result of their interconnections.⁷

III. Description of the AEM FCA

As discussed above, the AEM FCA is based on the *pro forma* GIA and contains language similar to other Commission-accepted Facilities Construction Agreements. The provisions of the AEM FCA are described below.

First, the "Whereas" clauses in the AEM FCA delineate the relationship between the Parties, as well as the circumstances that necessitate the AEM FCA.⁸

Second, Article 1 contains the definitions of terms used throughout the AEM FCA. These definitions are similar to corresponding definitions in the *pro forma* GIA. However, the AEM FCA does not include all of the *pro forma* GIA definitions because not all of them are applicable to a facilities construction agreement with an Affected System. In addition, the Parties added a definition for the term "Non-Breaching Party" to provide clarity in the termination provisions of the AEM FCA.⁹

⁶ See *Sw. Power Pool, Inc.*, Letter Order, Docket No. ER15-1304-000 (May 7, 2015); *Sw. Power Pool, Inc.*, Letter Order, Docket No. ER14-2030-000 (July 17, 2014); *Sw. Power Pool, Inc.*, Letter Order, Docket No. ER14-662-000 (Feb. 4, 2014); *Sw. Power Pool, Inc.*, Letter Order, Docket No. ER13-774-000 (Mar. 5, 2013); *Sw. Power Pool, Inc.*, Letter Order, Docket No. ER13-755-000 (Mar. 5, 2013); *Sw. Power Pool, Inc.*, Letter Order, Docket No. ER13-382-000 (Jan. 9, 2013); *Sw. Power Pool, Inc.*, Letter Order, Docket No. ER12-1802-000 (July 10, 2012); *Sw. Power Pool, Inc.*, Letter Order, Docket No. ER11-4390-000 (Oct. 13, 2011); *Sw. Power Pool, Inc.*, Letter Order, Docket No. ER11-4349-000 (Oct. 12, 2011).

⁷ See *Midwest Independent Transmission System Operator, Inc.*, Letter Order, Docket No. ER11-2155-000 (Jan. 13, 2011); *Midwest Independent Transmission System Operator, Inc.*, Letter Order, Docket No. ER10-2540-000 (Nov. 1, 2010); *Duke Electric Transmission*, 113 FERC ¶ 61,139 (2005).

⁸ See AEM FCA at Recitals.

⁹ See *id.* at Article 1.

The Honorable Kimberly D. Bose

September 21, 2016

Page 4

Third, Articles 2 and 11, which also are similar to the corresponding provisions of the *pro forma* GIA, contain provisions regarding the term and termination of the AEM FCA.¹⁰ Article 2 specifies that the AEM FCA shall be effective on the date on which the AEM FCA is made and entered into by the Parties. Article 2 of the AEM FCA does not include provisions of Article 2 of the *pro forma* GIA pertaining to a “GIA,” the operations of the generating facility, and the disconnection of the generating facility because these provisions are not applicable to the construction of an upgrade on an Affected System. Similar to Article 11 of the *pro forma* GIA, the termination provisions in Article 11 of the AEM FCA are necessary to insulate the Parties from financial loss in the event of the termination of the agreement.

Fourth, Article 3 provides the terms and conditions for the construction of network upgrades and system protection facility requirements under the AEM FCA.¹¹ This Article is necessary to ensure that the responsibilities for the construction of the network upgrades are clearly defined, and is largely consistent with the *pro forma* GIA. However, it contains some variations to accommodate the purpose of the AEM FCA, which is to govern the construction of an upgrade on an Affected System, not to govern the interconnection of generation to the SPP system. For example, Article 3 contains provisions governing the costs for network upgrades, which vary from the corresponding provisions in the *pro forma* GIA because the AEM FCA provisions need only pertain to costs for work on network upgrades on SPS’s system as a result of the interconnection of AEM’s Generating Facility on LCEC’s transmission system and not costs related to interconnection customer interconnection facilities, and transmission owner interconnection facilities associated with interconnecting a generator to the SPP system through a GIA. For the same reason, the other provisions in Article 3 of the AEM FCA are similarly more narrow in scope than the *pro forma* GIA.

Fifth, Article 5 provides a mechanism for the exchange of information among the Parties, which will facilitate the implementation of the AEM FCA.¹² Similarly, Article 16 contains provisions that facilitate the exchange of notices under the AEM FCA.¹³

Sixth, Article 12 provides that Parties to the AEM FCA can use subcontractors to perform their obligations under the AEM FCA, but use by a Party of other entities to perform its obligations will not relieve the Party of its obligations under the AEM FCA.¹⁴

¹⁰ See *id.* at Articles 2 and 11.

¹¹ See *id.* at Article 3.

¹² See *id.* at Article 5.

¹³ See *id.* at Article 16.

¹⁴ See *id.* at Article 12.

The Honorable Kimberly D. Bose
September 21, 2016
Page 5

This provision is necessary to allow the Parties to hire subcontractors, but still keep the Parties liable for their obligations under the AEM FCA.

Seventh, Article 17 contains miscellaneous provisions that are standard contract provisions including: waiver (Article 17.1 – Waiver); governing law (Article 17.2 – Governing Law); counterparts (Article 17.6 – Counterparts); how to resolve conflicts within the AEM FCA (Article 17.8 – Conflicts); and a clause signifying that the AEM FCA constitutes the final, complete agreement between the Parties (Article 17.5 – Entire Agreement).¹⁵

Eighth, Appendix A of the AEM FCA, like Appendix A of the *pro forma* GIA, contains detailed information on the network upgrades to be built under the AEM FCA, including the pertinent costs estimates and responsibility, transmission credits, construction schedule, and monthly payment schedule.¹⁶ Assigning cost responsibility to AEM for the network upgrade on the SPS transmission system is just and reasonable because the upgrade would not be necessary but for the interconnection of the Generating Facility to LCEC and the resultant impacts on the SPS and SPP transmission systems.

Ninth, Appendix B contains a form letter for the notification of completed construction of the network upgrades.¹⁷ This letter is consistent with the type of notification required for interconnection customers interconnecting to the SPP system.¹⁸

Finally, the AEM FCA contains the following provisions that are consistent with, or similar to, the *pro forma* GIA: (1) Article 3.1.2 (Suspension of Work); (2) Article 3.3 (Taxes); (3) Article 4 (Force Majeure); (4) Article 6 (Modification); (5) Article 7 (Invoicing and Payments); (6) Article 8 (Assignment); (7) Article 9 (Indemnity, Consequential Damages and Insurance); (8) Article 10 (Default); (9) Article 13 (Confidentiality); (10) Article 14 (Information Access and Audit Rights); (11) Article 15 (Disputes); and (12) Article 18 (Representations and Warranties).¹⁹ Some of the aforementioned Articles contain slight variations from the *pro forma* GIA because the AEM FCA governs upgrades on an Affected System rather than an interconnection on SPP's transmission system. For example, some of the provisions were modified to refer to the FCA instead of the GIA. Other variations remove terms from the *pro forma* GIA that are not applicable to an FCA. For example, the Parties removed Articles 6 (Testing

¹⁵ See *id.* at Article 17.

¹⁶ See *id.* at Appendix A.

¹⁷ See *id.* at Appendix B.

¹⁸ See *pro forma* GIA at Appendix E.

¹⁹ See AEM FCA at Articles 3.1.2, 3.3, 4, 6, 7, 8, 9, 10, 13, 14, 15, and 18.

The Honorable Kimberly D. Bose
 September 21, 2016
 Page 6

and Inspection), 7 (Metering), and 9 (Operations) of the *pro forma* GIA because of each of these Articles are not applicable to the FCA.

IV. Effective Date

SPP requests an effective date of September 12, 2016 for the AEM FCA. Therefore, pursuant to section 35.11 of the Commission's rules and regulations, 18 C.F.R. § 35.11, SPP requests a waiver of the Commission's 60-day notice requirement set forth at 18 C.F.R. § 35.3. Waiver is appropriate because the AEM FCA is being filed within 30 days of its requested effective date.²⁰ In addition, the Commission previously has granted waiver of the 60-day notice requirement for agreements not contained in the filing entities' Tariff when the agreements were filed within 30 days of the requested effective date.²¹

V. Notice and Communication

SPP requests that all correspondence and communications with respect to this filing should be sent to, and that the Secretary should include on the official service list, the following:

Tessie Kentner
 Senior Attorney
 Southwest Power Pool, Inc.
 201 Worthen Drive
 Little Rock, AR 72223
 Telephone: (501) 688-1782
tkentner@spp.org

Nicole Wagner
 Manager - Regulatory Policy
 Southwest Power Pool, Inc.
 201 Worthen Drive
 Little Rock, AR 72223
 Telephone: (501) 688-1642
jwagner@spp.org

²⁰ See *Prior Notice and Filing Requirements Under Part II of the Federal Power Act*, 64 FERC ¶ 61,139, at 61,983-84, *order on reh'g*, 65 FERC ¶ 61,081 (1993) (the Commission will grant waiver of the 60-day prior notice requirement "if service agreements are filed within 30 days after service commences.").

²¹ See *Sw. Power Pool, Inc.*, Letter Order, Docket No. ER16-1201-000 (May 6, 2016); *Sw. Power Pool, Inc.*, Letter Order, Docket No. ER15-2540-000 (Oct. 20, 2015); *Sw. Power Pool, Inc.*, Letter Order, Docket No. ER15-1680-000 (June 29, 2015); *Sw. Power Pool, Inc.*, Letter Order, Docket No. ER14-1795-000 (June 16, 2014).

The Honorable Kimberly D. Bose
September 21, 2016
Page 7

VI. Additional Information

A. Information Required by Section 35.13 of the Commission's Regulations, 18 C.F.R. § 35.13:

(1) Documents submitted with this filing:

In addition to this transmittal letter, SPP includes a copy of the AEM FCA with this filing.

(2) Effective date:

As discussed above, SPP respectfully requests that the Commission accept the AEM FCA with an effective date of September 12, 2016.

(3) Service:

SPP is serving a copy of this filing on the representatives for the Parties in the AEM FCA.

(4) Basis of Rate:

All charges under the AEM FCA will be determined in accordance with the Tariff and the AEM FCA.

The Honorable Kimberly D. Bose
September 21, 2016
Page 8

VII. Conclusion

For the foregoing stated reasons, SPP requests that the Commission accept the AEM FCA effective September 12, 2016.

Respectfully submitted,

/s/ Tessie Kentner

Tessie Kentner
Senior Attorney
Southwest Power Pool, Inc.
201 Worthen Drive
Little Rock, AR 72223
Telephone: (501) 688-1782
tkentner@spp.org

**Attorney for Southwest Power
Pool, Inc.**

**Southwest Power Pool, Inc.
Original Service Agreement No. 3247**

AFFECTED SYSTEMS' FACILITIES CONSTRUCTION AGREEMENT

Entered into by

Southwest Power Pool, Inc.,

And

Southwestern Public Service Company

And

AEM Wind LLC

Entered into on the 12th day of September, 2016

ASGI-2010-020

FACILITIES CONSTRUCTION AGREEMENT

THIS FACILITIES CONSTRUCTION AGREEMENT (sometimes hereinafter referred to as “Agreement”) is made and entered into this 12th day of September, 2016, by and among **AEM Wind LLC**, a limited liability company organized and existing under the laws of the State of Delaware (sometimes hereinafter referred to as “Interconnection Customer”), the **Southwest Power Pool, Inc.**, a non-profit, non-stock corporation organized and existing under the laws of the State of Arkansas (sometimes hereinafter referred to as “SPP” or “Transmission Provider”) and **Southwestern Public Service Company, A New Mexico corporation and wholly owned subsidiary of Xcel Energy**, (sometimes hereinafter referred to as “SPS” or “Transmission Owner”). Interconnection Customer, Transmission Owner, or Transmission Provider each may be referred to as a “Party” or collectively as the “Parties.”

RECITALS

WHEREAS, Transmission Owner and Interconnection Customer each owns or will own electric facilities and is or will be engaged in generation, transmission, distribution and/or sale of electric power and energy; and

WHEREAS, the Transmission Provider has functional control of the operations of the Transmission System, as defined herein, and is responsible for providing transmission and interconnection service on the transmission facilities under its control; and

WHEREAS, Interconnection Customer intends to own, and operate, or manage a 29.9MW Generating Facility consisting of thirteen (13) G.E. 2.3 MW wind generators interconnected to the 69kV bus of a new substation on the Lea County Electric Cooperative (“LCEC”) Crossroads-Tatum 69kV line located in Lea County, New Mexico (sometimes hereinafter referred to as the “Generating Facility” or “Facility”). The Generating Facility has an agreed upon Commercial Operation Date of September 30, 2017 pursuant to a duly executed Interconnection Agreement (“IA”) between LCEC and Interconnection Customer wherein the IA provides for interconnection service to interconnect the Generating Facility with the sub-transmission system of SPS, which system is interconnected to the SPS Transmission System; and

WHEREAS, the Transmission Provider has determined, after completion of an appropriate Facility Study that the Transmission System is affected by the interconnection of the Generating Facility to the LCEC transmission system and additions, modifications and upgrades must be made to certain existing facilities on the Transmission System to accommodate such interconnection; and

WHEREAS, Interconnection Customer has requested, and Transmission Provider and Transmission Owner have agreed, to enter into this Agreement with Interconnection Customer for the purpose of facilitating the interconnection of the Generating Facility by the construction of necessary Network Upgrades, Distribution Upgrades, System Protection Facilities, and Metering Equipment on the Transmission System;

NOW, THEREFORE, in consideration of and subject to the mutual covenants contained

herein, the Parties agree as follows:

ARTICLE 1 DEFINITIONS

Wherever used in this Agreement with initial capitalization, the following terms shall have the meanings specified or referred to in this Article 1. Terms used in this Agreement with initial capitalization not defined in this Article 1 shall have the meanings specified in the Transmission Provider Tariff:

- 1.1 **Affiliate** shall mean, with respect to a corporation, partnership or other entity, each such other corporation, partnership or other entity that directly or indirectly, through one or more intermediaries, controls, is controlled by, or is under common control with, such corporation, partnership or other entity.
- 1.2 **Applicable Laws and Regulations** shall mean all duly promulgated applicable federal, state and local laws, regulations, rules, ordinances, codes, decrees, judgments, directives, or judicial or administrative orders, permits and other duly authorized actions of any Governmental Authority.
- 1.3 **Applicable Reliability Council** shall mean the reliability council applicable to the Transmission System to which the Generating Facility is directly interconnected.
- 1.4 **Applicable Reliability Standards** shall mean the requirements and guidelines of NERC, the Applicable Reliability Council, and the Balancing Authority (as defined by NERC) of the Transmission System to which the Generating Facility is directly interconnected.
- 1.5 **Breach** shall mean the failure of a Party to perform or observe any material term or condition of this Agreement and shall include, but not be limited to, the events described in Article 10.1.
- 1.6 **Breaching Party** shall mean a Party that is in Breach of this Agreement.
- 1.7 **Commercial Operation** shall mean the status of a Generating Facility that has commenced generating electricity for sale, excluding electricity generated during Trial Operation.
- 1.8 **Commercial Operation Date** of a unit shall mean the date on which the Generating Facility commences Commercial Operation pursuant to the provisions of the applicable IA.
- 1.9 **Confidential Information** shall mean any confidential, proprietary or trade secret information of a plan, specification, pattern, procedure, design, device, list, concept, policy or compilation relating to the present or planned business of a Party, which is designated as confidential by the Party supplying the information, whether conveyed orally, electronically, in writing, through inspection, or otherwise.

- 1.10 Default** shall mean the failure of a Breaching Party to cure its Breach in accordance with Article 10 of this Agreement.
- 1.11 Distribution System** shall mean the Transmission Owner's facilities and equipment that are not included in the Transmission System. The voltage levels at which Distribution Systems operate differ among areas.
- 1.12 Distribution Upgrades** shall mean the additions, modifications, and upgrades to the Distribution System at or beyond the Point of Interconnection to facilitate interconnection of the Generating Facility and render the transmission service necessary to affect Interconnection Customer's wholesale sale of electricity in interstate commerce. Distribution Upgrades do not include Interconnection Facilities.
- 1.13 Effective Date** shall mean the date on which this Agreement becomes effective upon execution by the Parties subject to acceptance by the Commission.
- 1.14 Federal Power Act** shall mean the Federal Power Act, as amended, 16.U.S.C. §§ 791a et seq.
- 1.15 FERC** shall mean the Federal Energy Regulatory Commission, also known as Commission, or its successor.
- 1.16 Force Majeure** shall mean any act of God, labor disturbance, act of the public enemy, war, insurrection, riot, fire, storm or flood, explosion, breakage or accident to machinery or equipment, any order, regulation or restriction imposed by governmental, military or lawfully established civilian authorities, or any other cause beyond a Party's control. A Force Majeure event does not include an act of gross negligence or intentional wrongdoing by the Party claiming Force Majeure.
- 1.17 Reserved**
- 1.18 Good Utility Practice** shall mean any of the practices, methods and acts engaged in or approved by a significant portion of the electric industry during the relevant time period, or any of the practices, methods and acts which, in the exercise of reasonable judgment in light of the facts known to the time the decision was made, could have been expected to accomplish the desired result at a reasonable cost consistent with good business practices, reliability, safety and expedition. Good Utility Practice is not intended to be limited to the optimum practice, method, or act to the exclusion of all others, but rather to be acceptable practices, methods, or acts generally accepted in the region.
- 1.19 Governmental Authority** shall mean any federal, state, local or other governmental regulatory or administrative agency, court, commission, department, board, or other governmental subdivision, legislature, rulemaking board, tribunal, or other governmental authority having jurisdiction over the Parties, their respective facilities, or the respective services they provide, and exercising or entitled to exercise any administrative, executive, police, or taxing authority or power; provided, however, that such term does not include

Interconnection Customer, Transmission Provider, Transmission Owner, or any affiliate thereof.

- 1.20 In-Service Date** shall mean the date upon which the Interconnection Customer reasonably expects it will be ready to begin use of the Network Upgrades.
- 1.21 IRS** shall mean the Internal Revenue Service.
- 1.22 Loss** shall mean any and all losses relating to injury to or death of any person or damage to property, demand, suits, recoveries, costs and expenses, court costs, attorney fees, and all other obligations by or to third parties, arising out of or resulting from another Party's performance, or non-performance of its obligations under this Agreement on behalf of the indemnifying Party, except in cases of gross negligence or intentional wrongdoing by the indemnifying Party.
- 1.23 Material Modification** shall mean those modifications that have a material impact on the cost or timing of any Interconnection Request with a later Queue priority date.
- 1.24 Metering Equipment** shall mean all metering equipment installed or to be installed at the Generating Facility pursuant to this Agreement at the metering points, including but not limited to instrument transformers, MWh-meters, data acquisition equipment, transducers, remote terminal unit, communications equipment, phone lines, and fiber optics.
- 1.25 NERC** shall mean the North American Electric Reliability Corporation or its successor organization.
- 1.26 Network Upgrades** shall mean the additions, modifications, and upgrades to the Transmission System.
- 1.27 Non-Breaching Party** shall mean a Party that is not in Breach of this Agreement with regard to a specific event of Breach by another Party.
- 1.28 Reasonable Efforts** shall mean, with respect to an action required to be attempted or taken by a Party under this Agreement, efforts that are timely and consistent with Good Utility Practice and are otherwise substantially equivalent to those a Party would use to protect its own interests.
- 1.29 System Protection Facilities** shall mean the equipment, including necessary protection signal communications equipment, required to protect (1) the Transmission System or other delivery systems or other generating systems from faults or other electrical disturbances occurring at the Generating Facility and (2) the Generating Facility from faults or other electrical system disturbances occurring on the Transmission System or on other delivery systems or other generating systems to which the Transmission System is directly connected.
- 1.30 Tariff** shall mean the Transmission Provider's Tariff through which open access transmission service and Interconnection Service are offered, as filed with the

Commission, and as amended or supplemented from time to time, or any successor tariff.

- 1.31 Transmission Owner's Interconnection Facilities** shall mean all facilities and equipment owned, controlled or operated by the Transmission Owner from the Point of Change of Ownership to the Point of Interconnection, including any modifications, additions or upgrades to such facilities and equipment. Transmission Owner's Interconnection Facilities are sole use facilities and shall not include Distribution Upgrades or Network Upgrades.
- 1.32 Transmission System** shall mean the facilities owned by the Transmission Owner and controlled or operated by the Transmission Provider or Transmission Owner that are used to provide transmission service under the Tariff.

ARTICLE 2 TERM OF AGREEMENT

2.1 Effective Date. Subject to required regulatory authorizations, including, without limitation, acceptance by FERC under Section 205 of the Federal Power Act, this Agreement shall become effective on the date on which this Agreement is made and entered into by the Parties.

2.2 Term.

2.2.1 General. This Agreement shall become effective as provided in Article 2.1 and shall continue in full force and effect until the earlier of (i) payment of the Final Invoice as identified in the Appendix A, where applicable, by Interconnection Customer of the amount funded by Transmission Owner for Transmission Owner's design, procurement, construction and installation of the Network Upgrades, Distribution Upgrades, System Protection Facilities, and Metering Equipment provided in Appendix A; (ii) the Parties agree to mutually terminate this Agreement; or (iii) Interconnection Customer terminates this Agreement after providing Transmission Provider and Transmission Owner with written notice at least sixty (60) days prior to the proposed termination date, provided that Interconnection Customer has no outstanding contractual obligations to Transmission Provider or Transmission Owner under this Agreement. No termination of this Agreement shall be effective until the Parties have complied with all Applicable Laws and Regulations applicable to such termination. The term of this Agreement may be adjusted upon mutual agreement of the Parties, if the Commercial Operation Date for the Facility or the In-Service Date for the Network Upgrades, Distribution Upgrades, System Protection Facilities, and Metering Equipment is adjusted in accordance with the rules and procedures established by the Transmission Provider.

2.2.2 Termination Upon Default. In the event of a Default by a Party, the Non-Breaching Party or Parties shall have the termination rights described in Articles 10 and 11; provided, however, if the Default does not pose a threat to the reliability of the Transmission System, neither Transmission Provider nor Transmission Owner may terminate this Agreement if Interconnection Customer

is the Breaching Party and Interconnection Customer (i) has undertaken, in accordance with Article 10.1, to cure the Breach that led to the Default and has failed to cure the Breach for reasons other than Interconnection Customer's failure to diligently commence reasonable and appropriate steps to cure the Breach within the thirty (30) days allowed by Article 10.1, and (ii) compensates Transmission Provider or Transmission Owner within thirty (30) days for the amount of damage billed to Interconnection Customer by Transmission Provider or Transmission Owner for any damages, including costs and expenses, incurred by Transmission Provider or Transmission Owner as a result of such Default.

2.2.3 Consequences of Termination. In the event of a termination by any Party, other than a termination by Interconnection Customer due to a Breach by Transmission Owner, Interconnection Customer must pay Transmission Owner all amounts still due and payable for construction and installation of the Network Upgrades, Distribution Upgrades, System Protection Facilities, and Metering Equipment (including, without limitation, any equipment ordered related to such construction), plus all out-of-pocket expenses incurred by Transmission Owner in connection with the construction and installation of the Network Upgrades, Distribution Upgrades, System Protection Facilities, and Metering Equipment, through the date of termination, plus any actual costs which Transmission Owner (A) reasonably incurs in winding up work and construction demobilization and (B) reasonably incurs to ensure the safety of persons and property and the integrity and safe and reliable operation of the Transmission System. Transmission Owner agrees to use Reasonable Efforts to minimize such costs.

2.2.4 Material Adverse Change. In the event of a material change in law or regulation that adversely affects, or may reasonably be expected to adversely affect a Party's rights and/or obligations under this Agreement, the Parties shall negotiate in good faith any amendments to this Agreement necessary to adapt the terms of this Agreement to such change in law or regulation, and Transmission Provider shall file such amendments with FERC. If, within sixty (60) days after the occurrence of any event described in this Article 2.2.4, the Parties are unable to reach agreement as to any necessary amendments, the Parties may proceed under Article 15 to resolve any disputes related thereto; Transmission Provider shall have the right to make a unilateral filing with FERC to modify this Agreement pursuant to Section 205 or any other applicable provision of the Federal Power Act and FERC's rules and regulations thereunder, and Interconnection Customer shall have the right to make a unilateral filing with FERC to modify this Agreement pursuant to Section 206 or any other applicable provision of the Federal Power Act and FERC's rules and regulations thereunder; provided that a Party shall have the right to protest any such filing by another Party and to participate fully in any proceeding before FERC in which such modifications may be considered. If a Party is unable to fully perform this Agreement due to the occurrence of an event described in this Article 2.2.4 and such inability is not based on economic reasons, such Party shall not be deemed to be in Default of its obligations under this Agreement, provided that such Party is seeking dispute resolution under Article 15 or before FERC, to the extent that (i) such Party is unable to perform as a result of such an event and (ii) such Party acts in

accordance with its obligations under this Article 2.2.4.

- 2.3 Regulatory Filing.** In accordance with Applicable Laws and Regulations, Transmission Provider shall file this Agreement, and any amendment to this Agreement with FERC as a service agreement under the Transmission Provider Tariff. If Interconnection Customer has executed this Agreement or any amendment to this Agreement, Interconnection Customer shall not protest this Agreement or the amendment, shall reasonably cooperate with Transmission Provider with respect to such filing and shall provide any information, including the rendering of testimony or pleadings, as applicable, reasonably requested by Transmission Provider to the extent reasonably needed to comply with applicable regulatory requirements.
- 2.4 Survival.** The applicable provisions of this Agreement shall continue in effect after expiration, cancellation, or termination hereof to the extent necessary to provide for final billings, billing adjustments, and the determination and enforcement of liability and indemnification obligations arising from acts or events that occurred while this Agreement was in effect.
- 2.5 Termination Obligations.** Upon any termination pursuant to this Agreement, Interconnection Customer shall be responsible for the payment of all costs or other contractual obligations incurred prior to the termination date including previously incurred capital costs, penalties for early termination, costs of removal and site restoration.

ARTICLE 3

CONSTRUCTION OF NETWORK UPGRADES, DISTRIBUTION UPGRADES, SYSTEM PROTECTION FACILITIES, AND METERING EQUIPMENT

3.1 Construction.

3.1.1 Transmission Owner Obligations. Transmission Owner shall (or shall cause such action to) design, procure, construct and install, and Interconnection Customer shall pay, consistent with Article 3.2, the cost of, all Network Upgrades, Distribution Upgrades, System Protection Facilities, and Metering Equipment identified in Appendix A. All Network Upgrades, Distribution Upgrades, System Protection Facilities, and Metering Equipment designed, procured, constructed and installed by Transmission Owner pursuant to this Agreement shall satisfy all requirements of applicable safety and/or engineering codes, including those requirements of Transmission Owner and Transmission Provider, and comply with Good Utility Practice, and further, shall satisfy all Applicable Laws and Regulations.

3.1.2 Suspension of Work.

3.1.2.1 Conditions of Suspension. Interconnection Customer, upon written notice to Transmission Provider and Transmission Owner, may suspend, for a period not to exceed eighteen (18) months, work by Transmission Owner associated with the construction and installation of Transmission Owner's Network Upgrades,

Distribution Upgrades, System Protection Facilities, and Metering Equipment required under this Agreement under the following terms and conditions:

- i. Construction of Network Upgrades, Distribution Upgrades, System Protection Facilities, and Metering Equipment that are required to provide Interconnection Service to other Generating Facilities and for which Interconnection Customer shares cost responsibility cannot be suspended pursuant to this Article 3.1.2.
- ii. If the suspension period begins later than or extends beyond six (6) months following the Effective Date of the IA, the Interconnection Customer shall provide to the Transmission Owner security in the form described under Article 3.2.3 in an amount equal to the greater of:
 - a. the Interconnection Customer's allocated share of Network Upgrades, Distribution Upgrades, System Protection Facilities, and Metering Equipment as identified in Appendix A of this Agreement; or
 - b. \$5,000,000 if the Generating Facility is greater than or equal to 100 MW; or
 - c. \$2,500,000 if the Generating Facility is greater than or equal to 50 MW and less than 100 MW; or
 - d. \$1,000,000 if the Generating Facility is less than 50 MW; or
 - e. \$500,000 if the Generating Facility is less than or equal to 2 MW.
- iii. In the event that this Agreement is terminated under this Article 3.1.2, the Transmission Provider shall retain the security provided pursuant to Article 3.1.2.1 (ii) in the amount required to meet Interconnection Customer's obligations pursuant to this Agreement. Any difference between the security provided and Interconnection Customer's obligations shall be settled pursuant to Article 7.
- iv. In the event Interconnection Customer suspends work by Transmission Owner required under this Agreement pursuant to this Article 3.1.2 and has not requested Transmission Owner to resume the work required under this Agreement on or before the expiration of 18 months from the date of suspension, this Agreement shall be deemed terminated unless Article 4 applies.
- v. In the event Interconnection Customer suspends work by Transmission Owner required under this Agreement pursuant to this Article 3.1.2 and has not complied with the requirements of Article 3.1.2.1(ii) on or before the later of the expiration of 6 months following the effective date of the IA or the date the suspension is requested, this Agreement shall be deemed terminated by the Interconnection Customer.

- vi. In the event Interconnection Customer suspends work by Transmission Owner required under this Agreement pursuant to this Article 3.1.2, the Transmission System shall be left in a safe and reliable condition in accordance with Good Utility Practice and Transmission Owner's safety and reliability criteria. Interconnection Customer shall be responsible for all reasonable and necessary costs which Transmission Owner and Transmission Provider (i) have incurred pursuant to this Agreement prior to the suspension and (ii) incur in suspending such work, including any costs incurred to perform such work as may be necessary to ensure the safety of persons and property and the integrity of the Transmission System during such suspension and, if applicable, any costs incurred in connection with the cancellation or suspension of material, equipment and labor contracts which Transmission Owner cannot reasonably avoid; provided, however, that prior to canceling or suspending any such material, equipment or labor contract, Transmission Owner shall obtain Interconnection Customer's authorization to do so. Transmission Owner and Transmission Provider shall invoice Interconnection Customer for such costs pursuant to Article 7 and shall use due diligence to minimize its costs.
- vii. In the event Interconnection Customer provides written notice to resume work for those facilities for which work has been suspended pursuant to this Article 3.1.2, the Interconnection Customer shall receive a refund, including interest, of any payments provided in accordance with Article 3.1.2.1(ii) in excess of the sum of Interconnection Customer's allocated share of Network Upgrades, Distribution Upgrades, System Protection Facilities, and Metering Equipment costs and any costs incurred under Article 3.1.2.1(vi) within 30 days of the date of such notice.

3.1.2.2 Exemptions. The Interconnection Customer shall be exempt from the payments described under Article 3.1.2.1(ii)(b), 3.1.2.1(ii)(c) and 3.1.2.1(ii)(d) if the following occurs or suspension is requested for the following reasons:

- i. Construction of a Network Upgrade, Distribution Upgrades, System Protection Facility, and/or Metering Equipment or the Generating Facility is prevented by order of a Governmental Authority; or
- ii. Transmission Owner or Transmission Provider determines that a Force Majeure event prevents construction of a Network Upgrade, Distribution Upgrades, System Protection Equipment, and/or Metering Equipment.

3.1.2.3 Termination in the Event of a Material Modification. In the event Interconnection Customer suspends the performance of work by Transmission Owner pursuant to this Article 3.1.2 and modifies its Commercial Operation Date by three (3) years or more, this Agreement

shall be deemed terminated unless Interconnection Customer demonstrates that the change is not a Material Modification under FERC precedent.

3.1.2.4 Right to Suspend Due to Default. Transmission Owner reserves the right, upon written notice to Interconnection Customer, to suspend, at any time, work by Transmission Owner and the incurrence of additional expenses associated with the construction and installation of the Network Upgrades, Distribution Upgrades, System Protection Facilities, and Metering Equipment upon the occurrence of either a Breach that Interconnection Customer is unable to cure pursuant to Article 10 or an Event of Default pursuant to Article 10. Any form of suspension by Transmission Owner shall not be barred by Articles 2.2.2, 2.2.3 or 10.2, nor shall it affect Transmission Owner's right to terminate the work or this Agreement pursuant to Article 10. In such events, Interconnection Customer shall be responsible for costs which Transmission Owner incurs as set forth in Article 2.2.3.

3.1.3 Equipment Procurement. Transmission Owner shall commence design of Network Upgrades, Distribution Upgrades, System Protection Facilities, and Metering Equipment and procure necessary equipment as soon as practicable after all of the following conditions are satisfied, unless the Parties otherwise agree in writing:

3.1.3.1 Transmission Provider has completed an affected system facilities study detailing the costs of the facilities on the Transmission Provider System;

3.1.3.2 Transmission Owner has received written authorization to proceed with design and procurement from Interconnection Customer by the date specified in Appendix A, Milestones; and

3.1.3.3 Interconnection Customer has provided security to Transmission Provider in accordance with Article 3.2.3 by the dates specified in Appendix A, Milestones.

3.1.4 Construction Commencement. Transmission Owner shall commence construction of Network Upgrades, Distribution Upgrades, System Protection Facilities, and Metering Equipment for which it is responsible as soon as practicable after the following additional conditions are satisfied:

3.1.4.1 Approval of the appropriate Governmental Authority has been obtained for any facilities requiring regulatory approval;

3.1.4.2 Necessary real property rights and rights-of-way have been obtained, to the extent required for the construction of a discrete aspect of Network Upgrades, Distribution Upgrades, System Protection Facilities, and Metering Equipment;

3.1.4.3 Transmission Owner has received written authorization to proceed with construction from Interconnection Customer by the date specified in Appendix A, Milestones; and

3.1.4.4 Interconnection Customer has provided security to Transmission Provider in accordance with Article 3.2.3 by the dates specified in Appendix A, Milestones.

3.1.5 Lands of Other Property Owners. If any part of the Network Upgrades, Distribution Upgrades, System Protection Facilities, and/or Metering Equipment is to be installed on property owned by persons other than Interconnection Customer or Transmission Owner, the Transmission Owner shall at Interconnection Customer's expense use efforts, similar in nature and extent to those that it typically undertakes on its own behalf or on behalf of its Affiliates, including use of its eminent domain authority to the extent permitted and consistent with Applicable Laws and Regulations and, to the extent consistent with such Applicable Laws and Regulations, to procure from such persons any rights of use, licenses, rights of way and easements that are necessary to construct, operate, maintain, test, inspect, replace or remove the Network Upgrades, Distribution Upgrades, System Protection Facilities, and/or Metering Equipment upon such property.

3.1.6 Construction Status. Transmission Owner shall keep Interconnection Customer and Transmission Provider advised periodically as to the progress of its respective design, procurement and construction efforts as described in Appendix A. Interconnection Customer may, at any time, request a progress report from Transmission Owner, with a copy to be provided to Transmission Provider. If, at any time, Interconnection Customer determines that the completion of the Network Upgrades, System Protection Facilities, and/or Metering Equipment will not be required until after the specified In-Service Date, Interconnection Customer will provide written notice to Transmission Owner and Transmission Provider of such later date upon which the completion of the Network Upgrades, System Protection Facilities, and/or Metering Equipment would be required. Transmission Owner may delay the In-Service Date of the Network Upgrades, System Protection Facilities, and/or Metering Equipment accordingly.

3.1.7 Timely Completion. Transmission Owner shall use Reasonable Efforts to design, procure, construct, install, and test the Network Upgrades, Distribution Upgrades, System Protection Facilities, and/or Metering Equipment in accordance with the schedule set forth in Appendix A. If any event occurs that will affect the time for completion of the Network Upgrades, Distribution Upgrades, System Protection Facilities, and/or Metering Equipment, or the ability to complete any of them, Transmission Owner and/or Transmission Provider shall promptly notify Interconnection Customer, with a copy to the other Party. In such circumstances, Transmission Provider shall, within fifteen (15) days of such notice, convene a technical meeting with Interconnection Customer and Transmission Owner to evaluate the alternatives available to Interconnection Customer. Transmission Owner and/or Transmission Provider shall also make available to Interconnection

Customer all studies and work papers related to the event and corresponding delay, including all information that is in the possession of Transmission Provider or Transmission Owner that is reasonably needed by Interconnection Customer to evaluate alternatives. Transmission Owner shall, at Interconnection Customer's request and expense, use Reasonable Efforts to accelerate its work under this Agreement to meet the schedule set forth in Appendix A, provided that Interconnection Customer authorizes such actions and the costs associated therewith in advance.

3.2 Interconnection Costs and Credits.

3.2.1 Costs. Interconnection Customer shall pay to Transmission Owner costs (including taxes and financing costs) associated with seeking and obtaining all necessary approvals and of designing, engineering, constructing, and testing the Network Upgrades, Distribution Upgrades, System Protection Facilities, and/or Metering Equipment, as identified in Appendix A, in accordance with the cost recovery method provided herein.

Transmission Owner shall install, at Interconnection Customer's expense, any Transmission Owner's System Protection Facilities and/or Metering Equipment as identified in Appendix A that may be required on the Transmission Owner's Interconnection Facilities or the Transmission Owner's transmission or distribution facilities as a result of the interconnection of the Generating Facility and the Interconnection Customer's Interconnection Facilities.

3.2.2 Credits.

3.2.2.1 Credits for Amounts Advanced for Network Upgrades.

Interconnection Customer shall be entitled to credits in accordance with Attachment Z2 of the Tariff for any Network Upgrades including any tax gross-up or other tax-related payments associated with Network Upgrades.

3.2.2.2 Notwithstanding any other provision of this Agreement, nothing herein shall be construed as relinquishing or foreclosing any rights, including but not limited to firm transmission rights, capacity rights, transmission congestion rights, or transmission credits, that Interconnection Customer, shall be entitled to, now or in the future under any other agreement or tariff as a result of, or otherwise associated with, the transmission capacity, if any, created by the Network Upgrades, including the right to obtain transmission credits for transmission service that is not associated with the Generating Facility.

3.2.3 Provision of Security. At least thirty (30) Calendar Days prior to the commencement of the procurement, installation, or construction of a discrete portion of Network Upgrades, Distribution Upgrades, System Protection Facilities, and/or Metering Equipment as defined in Appendix A of this Agreement, Interconnection Customer shall provide Transmission Provider a letter of credit or other form of security that is reasonably acceptable to

Transmission Provider and is consistent with the Uniform Commercial Code of the jurisdiction identified in Article 17.2.

Such security for payment shall be in an amount sufficient to cover the costs for constructing, procuring and installing the applicable portion of Network Upgrades, Distribution Upgrades, System Protection Facilities, and/or Metering Equipment Network Upgrades and System Protection Facilities as defined in Appendix A of this Agreement and shall be reduced on a dollar-for-dollar basis for payments made to Transmission Provider or Transmission Owner for these purposes. If Interconnection Customer requests suspension pursuant to Article 3.1.2, Interconnection Customer may be required to provide Transmission Provider security in the form described above for its allocated share of Network Upgrades, Distribution Upgrades, System Protection Facilities, and/or Metering Equipment as defined in Appendix A of this Agreement. In addition, the letter of credit must be issued by a financial institution reasonably acceptable to Transmission Provider and must specify a reasonable expiration date.

3.3 Taxes.

3.3.1 Interconnection Customer Payments Not Taxable. The Parties intend that all payments or property transfers made by Interconnection Customer to Transmission Owner for the installation of Transmission Owner's Interconnection Facilities and the Network Upgrades, Distribution Upgrades, System Protection Facilities, and/or Metering Equipment shall be non-taxable, either as contributions to capital, or as an advance, in accordance with the Internal Revenue Code and any applicable state income tax laws and shall not be taxable as contributions in aid of construction or otherwise under the Internal Revenue Code and any applicable state income tax laws.

3.3.2 Representations and Covenants. In accordance with IRS Notice 2001-82 and IRS Notice 88-129, Interconnection Customer represents and covenants that (i) ownership of the electricity generated at the Generating Facility will pass to another party prior to the transmission of the electricity on the Transmission System, (ii) for income tax purposes, the amount of any payments and the cost of any property transferred to Transmission Owner for Transmission Owner's Interconnection Facilities will be capitalized by Interconnection Customer as an intangible asset and recovered using the straight-line method over a useful life of twenty (20) years, and (iii) any portion of Transmission Owner's Interconnection Facilities that is a "dual-use intertie," within the meaning of IRS Notice 88-129, is reasonably expected to carry only a de minimis amount of electricity in the direction of the Generating Facility. For this purpose, "de minimis amount" means no more than 5 percent of the total power flows in both directions, calculated in accordance with the "5 percent test" set forth in IRS Notice 88-129. This is not intended to be an exclusive list of the relevant conditions that must be met to conform to IRS requirements for non-taxable treatment.

At Transmission Owner's request, Interconnection Customer shall provide Transmission Owner with a report from an independent engineer confirming its

representation in clause (iii), above. Transmission Owner represents and covenants that the cost of Transmission Owner's Interconnection Facilities paid for by Interconnection Customer will have no net effect on the base upon which rates are determined.

3.3.3 Indemnification for the Cost Consequences of Current Tax Liability Imposed Upon the Transmission Owner. Notwithstanding Article 3.3.1, Interconnection Customer shall protect, indemnify and hold harmless Transmission Owner from the cost consequences of any current tax liability imposed against Transmission Owner as the result of payments or property transfers made by Interconnection Customer to Transmission Owner under this Agreement for Interconnection Facilities, as well as any interest and penalties, other than interest and penalties attributable to any delay caused by Transmission Owner.

Transmission Owner shall not include a gross-up for the cost consequences of any current tax liability in the amounts it charges Interconnection Customer under this Agreement unless (i) Transmission Owner has determined, in good faith, that the payments or property transfers made by Interconnection Customer to Transmission Owner should be reported as income subject to taxation or (ii) any Governmental Authority directs Transmission Owner to report payments or property as income subject to taxation; provided, however, that Transmission Owner may require Interconnection Customer to provide security for Interconnection Facilities, in a form reasonably acceptable to Transmission Owner (such as a parental guarantee or a letter of credit), in an amount equal to the cost consequences of any current tax liability under this Article 3.3. Interconnection Customer shall reimburse Transmission Owner for such costs on a fully grossed-up basis, in accordance with Article 3.3.4, within thirty (30) Calendar Days of receiving written notification from Transmission Owner of the amount due, including detail about how the amount was calculated.

The indemnification obligation shall terminate at the earlier of (1) the expiration of the ten year testing period and the applicable statute of limitation, as it may be extended by Transmission Owner upon request of the IRS, to keep these years open for audit or adjustment, or (2) the occurrence of a subsequent taxable event and the payment of any related indemnification obligations as contemplated by this Article 3.3.

3.3.4 Tax Gross-Up Amount. Interconnection Customer's liability for the cost consequences of any current tax liability under this Article 3.3 shall be calculated on a fully grossed-up basis. Except as may otherwise be agreed to by the Parties, this means that Interconnection Customer will pay Transmission Owner, in addition to the amount paid for the Interconnection Facilities, Network Upgrades, Distribution Upgrades, System Protection Facilities, and/or Metering Equipment, an amount equal to (1) the current taxes imposed on Transmission Owner ("Current Taxes") on the excess of (a) the gross income realized by Transmission Owner as a result of payments or property transfers made by Interconnection Customer to Transmission Owner under this Agreement (without regard to any payments under this Article 3.3) (the "Gross Income Amount") over (b) the

present value of future tax deductions for depreciation that will be available as a result of such payments or property transfers (the “Present Value Depreciation Amount”), plus (2) an additional amount sufficient to permit Transmission Owner to receive and retain, after the payment of all Current Taxes, an amount equal to the net amount described in clause (1).

For this purpose, (i) Current Taxes shall be computed based on Transmission Owner’s composite federal and state tax rates at the time the payments or property transfers are received and Transmission Owner will be treated as being subject to tax at the highest marginal rates in effect at that time (the “Current Tax Rate”), and (ii) the Present Value Depreciation Amount shall be computed by discounting Transmission Owner’s anticipated tax depreciation deductions as a result of such payments or property transfers by Transmission Owner’s current weighted average cost of capital. Thus, the formula for calculating Interconnection Customer’s liability to Transmission Owner pursuant to this Article 3.3.4 can be expressed as follows: $(\text{Current Tax Rate} \times (\text{Gross Income Amount} - \text{Present Value of Tax Depreciation})) / (1 - \text{Current Tax Rate})$. Interconnection Customer’s estimated tax liability in the event taxes are imposed shall be stated in Appendix A, Interconnection Facilities, Network Upgrades, Distribution Upgrades, System Protection Facilities, and/or Metering Equipment.

3.3.5 Private Letter Ruling or Change or Clarification of Law. At Interconnection Customer’s request and expense, Transmission Owner shall file with the IRS a request for a private letter ruling as to whether any property transferred or sums paid, or to be paid, by Interconnection Customer to Transmission Owner under this Agreement are subject to federal income taxation. Interconnection Customer will prepare the initial draft of the request for a private letter ruling, and will certify under penalties of perjury that all facts represented in such request are true and accurate to the best of Interconnection Customer’s knowledge. Transmission Owner and Interconnection Customer shall cooperate in good faith with respect to the submission of such request.

Transmission Owner shall keep Interconnection Customer fully informed of the status of such request for a private letter ruling and shall execute either a privacy act waiver or a limited power of attorney, in a form acceptable to the IRS, that authorizes Interconnection Customer to participate in all discussions with the IRS regarding such request for a private letter ruling. Transmission Owner shall allow Interconnection Customer to attend all meetings with IRS officials about the request and shall permit Interconnection Customer to prepare the initial drafts of any follow-up letters in connection with the request.

3.3.6 Subsequent Taxable Events. If, within ten (10) years from the date on which the relevant Transmission Owner’s Interconnection Facilities are placed in service, (i) Interconnection Customer Breaches the covenants contained in Article 3.3.2, (ii) a “disqualification event” occurs within the meaning of IRS Notice 88-129, or (iii) this Agreement terminates and Transmission Owner retains ownership of the Interconnection Facilities, Network Upgrades, Distribution Upgrades, System Protection Facilities, and/or Metering Equipment,

Interconnection Customer shall pay a tax gross-up for the cost consequences of any current tax liability imposed on Transmission Owner, calculated using the methodology described in Article 3.3.4 and in accordance with IRS Notice 90-60.

3.3.7 Contests. In the event any Governmental Authority determines that Transmission Owner's receipt of payments or property constitutes income that is subject to taxation, Transmission Owner shall notify Interconnection Customer, in writing, within thirty (30) Calendar Days of receiving notification of such determination by a Governmental Authority. Upon the timely written request by Interconnection Customer and at Interconnection Customer's sole expense, Transmission Owner may appeal, protest, seek abatement of, or otherwise oppose such determination. Upon Interconnection Customer's written request and sole expense, Transmission Owner may file a claim for refund with respect to any taxes paid under this Article 3.3, whether or not it has received such a determination. Transmission Owner reserves the right to make all decisions with regard to the prosecution of such appeal, protest, abatement or other contest, including the selection of counsel and compromise or settlement of the claim, but Transmission Owner shall keep Interconnection Customer informed, shall consider in good faith suggestions from Interconnection Customer about the conduct of the contest, and shall reasonably permit Interconnection Customer or an Interconnection Customer representative to attend contest proceedings.

Interconnection Customer shall pay to Transmission Owner on a periodic basis, as invoiced by Transmission Owner, Transmission Owner's documented reasonable costs of prosecuting such appeal, protest, abatement or other contest. At any time during the contest, Transmission Owner may agree to a settlement either with Interconnection Customer's consent or after obtaining written advice from nationally-recognized tax counsel, selected by Transmission Owner, but reasonably acceptable to Interconnection Customer, that the proposed settlement represents a reasonable settlement given the hazards of litigation. Interconnection Customer's obligation shall be based on the amount of the settlement agreed to by Interconnection Customer, or if a higher amount, so much of the settlement that is supported by the written advice from nationally-recognized tax counsel selected under the terms of the preceding sentence. The settlement amount shall be calculated on a fully grossed-up basis to cover any related cost consequences of the current tax liability. Any settlement without Interconnection Customer's consent or such written advice will relieve Interconnection Customer from any obligation to indemnify Transmission Owner for the tax at issue in the contest.

3.3.8 Refund. In the event that (a) a private letter ruling is issued to Transmission Owner which holds that any amount paid or the value of any property transferred by Interconnection Customer to Transmission Owner under the terms of this Agreement is not subject to federal income taxation, (b) any legislative change or administrative announcement, notice, ruling or other determination makes it reasonably clear to Transmission Owner in good faith that any amount paid or the value of any property transferred by Interconnection Customer to Transmission Owner under the terms of this Agreement is not taxable to Transmission Owner, (c) any abatement, appeal, protest, or other contest results in a determination that

any payments or transfers made by Interconnection Customer to Transmission Owner are not subject to federal income tax, or (d) if Transmission Owner receives a refund from any taxing authority for any overpayment of tax attributable to any payment or property transfer made by Interconnection Customer to Transmission Owner pursuant to this Agreement, Transmission Owner shall promptly refund to Interconnection Customer the following:

- (i) any payment made by Interconnection Customer under this Article 3.3 for taxes that is attributable to the amount determined to be non-taxable, together with interest thereon,
- (ii) interest on any amount paid by Interconnection Customer to Transmission Owner for such taxes which Transmission Owner did not submit to the taxing authority, calculated in accordance with the methodology set forth in FERC's regulations at 18 CFR §35.19a(a)(2)(iii) from the date payment was made by Interconnection Customer to the date Transmission Owner refunds such payment to Interconnection Customer, and
- (iii) with respect to any such taxes paid by Transmission Owner, any refund or credit Transmission Owner receives or to which it may be entitled from any Governmental Authority, interest (or that portion thereof attributable to the payment described in clause (i), above) owed to Transmission Owner for such overpayment of taxes (including any reduction in interest otherwise payable by Transmission Owner to any Governmental Authority resulting from an offset or credit); provided, however, that Transmission Owner will remit such amount promptly to Interconnection Customer only after and to the extent that Transmission Owner has received a tax refund, credit or offset from any Governmental Authority for any applicable overpayment of income tax related to Transmission Owner's Interconnection Facilities.

The intent of this provision is to leave the Parties, to the extent practicable, in the event that no taxes are due with respect to any payment for Interconnection Facilities, Network Upgrades, Distribution Upgrades, System Protection Facilities, and/or Metering Equipment hereunder, in the same position they would have been in had no such tax payments been made.

3.3.9 Taxes Other Than Income Taxes. Upon the timely request by Interconnection Customer, and at Interconnection Customer's sole expense, Transmission Owner may appeal, protest, seek abatement of, or otherwise contest any tax (other than federal or state income tax) asserted or assessed against Transmission Owner for which Interconnection Customer may be required to reimburse Transmission Owner under the terms of this Agreement. Interconnection Customer shall pay to Transmission Owner on a periodic basis, as invoiced by Transmission Owner, Transmission Owner's documented reasonable costs of prosecuting such appeal, protest, abatement, or other contest. Interconnection Customer and Transmission Owner shall cooperate in good faith with respect to any such contest. Unless the payment of such taxes is a prerequisite to an appeal or abatement or cannot be

deferred, no amount shall be payable by Interconnection Customer to Transmission Owner for such taxes until they are assessed by a final, non-appealable order by any court or agency of competent jurisdiction. In the event that a tax payment is withheld and ultimately due and payable after appeal, Interconnection Customer will be responsible for all taxes, interest and penalties, other than penalties attributable to any delay caused by Transmission Owner.

- 3.4 Tax Status.** All Parties shall cooperate with each other to maintain their tax status. Nothing in this Agreement is intended to adversely affect any Party's tax exempt status with respect to the issuance of bonds including, but not limited to, local furnishing bonds.

ARTICLE 4 FORCE MAJEURE

- 4.1** Economic hardship is not considered a Force Majeure event.
- 4.2** No Party shall be considered to be in Default with respect to any obligation hereunder, (including obligations under Article 3), other than the obligation to pay money when due, if prevented from fulfilling such obligation by Force Majeure. A Party unable to fulfill any obligation hereunder (other than an obligation to pay money when due) by reason of Force Majeure shall give notice and the full particulars of such Force Majeure to the other Parties in writing or by telephone as soon as reasonably possible after the occurrence of the cause relied upon. Telephone notices given pursuant to this article shall be confirmed in writing as soon as reasonably possible and shall specifically state full particulars of the Force Majeure, the time and date when the Force Majeure occurred and when the Force Majeure is reasonably expected to cease. The Party affected shall exercise due diligence to remove such disability with reasonable dispatch, but shall not be required to accede or agree to any provision not satisfactory to it in order to settle and terminate a strike or other labor disturbance.

ARTICLE 5 INFORMATION REPORTING

- 5.1 Information Reporting Obligations.** Each Party shall, in accordance with Good Utility Practice, promptly provide to the other Parties all relevant information, documents, or data regarding the Party's facilities and equipment which may reasonably be expected to pertain to the reliability of the other Party's facilities and equipment and which has been reasonably requested by the other Party.
- 5.2 Non-Force Majeure Reporting.** A Party shall notify the other Parties when it becomes aware of its inability to comply with the provisions of this Agreement for a reason other than Force Majeure. The Parties agree to cooperate with each other and provide necessary information regarding such inability to comply, including, but not limited to, the date, duration, reason for the inability to comply, and corrective actions taken or planned to be taken with respect to such inability to comply. In the event of Force Majeure, a Party unable to comply with the provisions of this Agreement shall notify the other Parties in accordance with the provisions of Article 4.

ARTICLE 6 MODIFICATION

- 6.1 General.** Each Party may undertake modifications to its facilities. If a Party plans to undertake a modification that reasonably may be expected to affect another Party's facilities, that Party shall provide to the other Parties sufficient information regarding such modification so that the other Parties may evaluate the potential impact of such modification prior to commencement of the work. Such information shall be deemed to be confidential hereunder and shall include information concerning the timing of such modifications and whether such modifications are expected to interrupt the flow of electricity from the Generating Facility. The Party desiring to perform such work shall provide the relevant drawings, plans, and specifications to the other Parties at least ninety (90) Calendar Days in advance of the commencement of the work or such shorter period upon which the Parties may agree, which agreement shall not unreasonably be withheld, conditioned or delayed.

In the case of Generating Facility modifications that do not require Interconnection Customer to re-submit an interconnection request, Transmission Owner shall provide, within thirty (30) Calendar Days (or such other time as the Parties may agree), an estimate of any additional modifications to the Transmission System, Transmission Owner's Interconnection Facilities, Network Upgrades, Distribution Upgrades, System Protection Facilities, and Metering Equipment necessitated by such Interconnection Customer modification and a good faith estimate of the costs thereof.

- 6.2 Standards.** Any additions, modifications, or replacements made to a Party's facilities shall be designed, constructed and operated in accordance with this Agreement and Good Utility Practice.
- 6.3 Modification Costs.** Interconnection Customer shall not be directly assigned for the costs of any additions, modifications, or replacements that Transmission Owner makes to Transmission Owner's Interconnection Facilities or the Transmission System to facilitate the interconnection of a third party to Transmission Owner's Interconnection Facilities or the Transmission System, or to provide transmission service to a third party under Transmission Provider's Tariff. Interconnection Customer shall be responsible for the costs of any additions, modifications, or replacements to Interconnection Customer's Interconnection Facilities that may be necessary to maintain or upgrade such Interconnection Customer's Interconnection Facilities consistent with Applicable Laws and Regulations, Applicable Reliability Standards or Good Utility Practice.

ARTICLE 7 INVOICING AND PAYMENTS

The terms of this Article 7 apply to billing between the Parties for construction and operation and maintenance charges. All other billing will be handled according to the Tariff.

- 7.1 General.** Each Party shall submit to the other Party, on a monthly basis, invoices of amounts due for the preceding month. Each invoice shall state the month to which the

invoice applies and fully describe the services and equipment provided. The Parties may discharge mutual debts and payment obligations due and owing to each other on the same date through netting, in which case all amounts a Party owes to the other Party under this Agreement, including interest payments or credits, shall be netted so that only the net amount remaining due shall be paid by the owing Party.

- 7.2 Final Invoice.** Within six (6) months after completion of the construction of Interconnection Facilities, Network Upgrades, Distribution Upgrades, System Protection Facilities, and Metering Equipment as identified in Appendix A, the Interconnection Customer shall receive an invoice of the final cost due under this Agreement, including any applicable cost due to termination, which shall set forth such costs in sufficient detail to enable Interconnection Customer to compare the actual costs with the estimates and to ascertain deviations, if any, from the cost estimates. Interconnection Customer shall receive a refund of any amount by which the actual payment by Interconnection Customer for estimated costs exceeds the actual costs of construction within thirty (30) Calendar Days of the issuance of such final construction invoice.
- 7.3 Payment.** Invoices shall be rendered to the paying Party at the address specified in Section 16.2. The Party receiving the invoice shall pay the invoice within thirty (30) Calendar Days of receipt. All payments shall be made in immediately available funds payable to the other Party, or by wire transfer to a bank named and account designated by the invoicing Party. Payment of invoices by either Party will not constitute a waiver of any rights or claims either Party may have under this Agreement.
- 7.4 Disputes.** In the event of a billing dispute between the Parties, Transmission Owner, and Transmission Provider shall continue to provide Interconnection Service under this Agreement as long as Interconnection Customer: (i) continues to make all payments not in dispute; and (ii) pays to Transmission Owner or into an independent escrow account the portion of the invoice in dispute, pending resolution of such dispute. If Interconnection Customer fails to meet this requirement for continuation of service, then Transmission Owner may provide notice to Interconnection Customer of a Default pursuant to Article 10. Within thirty (30) Calendar Days after the resolution of the dispute, the Party that owes money to the other Party shall pay the amount due with interest calculated in accord with the methodology set forth in FERC's regulations at 18 C.F.R. § 35.19a(a)(2)(iii).

ARTICLE 8 ASSIGNMENT

- 8.1 Assignment.** This Agreement may be assigned by any Party only with the written consent of the other Parties; provided that a Party may assign this Agreement without the consent of the other Parties to any affiliate of the assigning Party with an equal or greater credit rating and with the legal authority and operational ability to satisfy the obligations of the assigning Party under this Agreement; and provided further that Interconnection Customer shall have the right to assign this Agreement, without the consent of either Transmission Provider or Transmission Owner, for collateral security purposes to aid in providing financing for the Facility, provided that Interconnection Customer will promptly notify Transmission Provider and Transmission Owner of any such assignment.

Any financing arrangement entered into by Interconnection Customer pursuant to this Article will provide that prior to or upon the exercise of the secured Party's, trustee's or assignment rights pursuant to said arrangement, the secured creditor, the trustee or mortgagee will notify the Transmission Provider and Transmission Owner of the date and particulars of any such exercise of assignment right(s), including providing Transmission Provider and Transmission Owner with proof that it meets the requirements of Article 3.2.3. Any attempted assignment that violates this Article is void and ineffective. Any assignment under this Agreement shall not relieve a Party of its obligations, nor shall a Party's obligations be enlarged, in whole or in part, by reason thereof. Where required, consent to assignment will not be unreasonably withheld, conditioned or delayed.

ARTICLE 9 INDEMNITY, CONSEQUENTIAL DAMAGES AND INSURANCE

9.1 General. To the extent permitted by State law, the Parties shall at all times indemnify, defend, and hold the other Parties harmless from, any and all damages, losses, claims, including claims and actions relating to injury to or death of any person or damage to property, demand, suits, recoveries, costs and expenses, court costs, attorney fees, and all other obligations by or to third parties, arising out of or resulting from the other parties' action or inactions of its obligations under this Agreement on behalf of the indemnifying party, except in cases of gross negligence or intentional wrongdoing by the indemnified party.

9.1.1 Indemnified Party. If an indemnified party is entitled to indemnification under this Article 9 as a result of a claim by a third party, and the indemnifying party fails, after notice and reasonable opportunity to proceed under Article 9.1, to assume the defense of such claim, such Indemnified Party may at the expense of the Indemnifying Party contest, settle or consent to the entry of any judgment with respect to, or pay in full, such claim.

9.1.2 Indemnifying Party. If an Indemnifying Party is obligated to indemnify and hold any Indemnified Party harmless under this Article 9, the amount owing to the Indemnified Party shall be the amount of such Indemnified Party's actual cost, net of any insurance or other recovery.

9.1.3 Indemnity Procedures. Promptly after receipt by an Indemnified Party of any claim or notice of the commencement of any action or administrative or legal proceeding or investigation as to which the indemnity provided for in Article 9.1 may apply, the Indemnified Party shall notify the Indemnifying Party of such fact. Any failure of or delay in such notification shall not affect a Party's indemnification obligation unless such failure or delay is materially prejudicial to the Indemnifying Party.

The Indemnifying Party shall have the right to assume the defense thereof with counsel designated by such Indemnifying Party and reasonably satisfactory to the Indemnified Party. If the defendants in any such action include one or more Indemnified Parties and the Indemnifying Party and if the Indemnified Party reasonably concludes that there may be legal defenses available to it and/or other

Indemnified Parties which are different from or additional to those available to the Indemnifying Party, the Indemnified Party shall have the right to select separate counsel to assert such legal defenses and to otherwise participate in the defense of such action on its own behalf. In such instances, the Indemnifying Party shall only be required to pay the fees and expenses of one additional attorney to represent an Indemnified Party or Indemnified Parties having such differing or additional legal defenses.

The Indemnified Party shall be entitled, at its expense, to participate in any such action, suit or proceeding, the defense of which has been assumed by the Indemnifying Party. Notwithstanding the foregoing, the Indemnifying Party (i) shall not be entitled to assume and control the defense of any such action, suit or proceedings if and to the extent that, in the opinion of the Indemnified Party and its counsel, such action, suit or proceeding involves the potential imposition of criminal liability on the Indemnified Party, or there exists a conflict or adversity of interest between the Indemnified Party and the Indemnifying Party, in such event the Indemnifying Party shall pay the reasonable expenses of the Indemnified Party, and (ii) shall not settle or consent to the entry of any judgment in any action, suit or proceeding without the consent of the Indemnified Party, which shall not be reasonably withheld, conditioned or delayed.

9.2 Consequential Damages. To the extent permitted by State law, in no event shall any Party be liable to any other Party under any provision of this Agreement for any losses, damages, costs or expenses for any special, indirect, incidental, consequential, or punitive damages, including but not limited to loss of profit or revenue, loss of the use of equipment, cost of capital, cost of temporary equipment or services, whether based in whole or in part in contract, in tort, including negligence, strict liability, or any other theory of liability; provided, however, that damages for which a Party may be liable to another Party under another agreement will not be considered to be special, indirect, incidental, or consequential damages hereunder.

9.3 Insurance. Interconnection Customer and Transmission Owner shall at their own expense, maintain in force throughout the period of this Agreement, and until released by all other Parties, the following minimum insurance coverages, with insurers authorized to do business in the state where Transmission Owner is located:

9.3.1 Employers' Liability and Workers' Compensation Insurance providing statutory benefits in accordance with the laws and regulations of the state in which the Point of Interconnection is located. The minimum limits for the Employers' Liability insurance shall be One Million Dollars (\$1,000,000) each accident bodily injury by accident, One Million Dollars (\$1,000,000) each employee bodily injury by disease, and One Million Dollars (\$1,000,000) policy limit bodily injury by disease.

9.3.2 Commercial General Liability Insurance including premises and operations, personal injury, broad form property damage, broad form blanket contractual liability coverage (including coverage for the contractual indemnification) products and completed operations coverage, coverage for explosion, collapse and

underground hazards (if applicable), independent contractors coverage, coverage for pollution (if exposure is present) and punitive or exemplary damages, with minimum limits of One Million Dollars (\$1,000,000) each occurrence/Two Million Dollars (\$2,000,000) general aggregate and Two Million Dollars (\$2,000,000) products and completed operations aggregate combined single limit for personal injury, bodily injury, including death and property damage.

- 9.3.3** Comprehensive Automobile Liability Insurance for coverage of owned and non-owned and hired vehicles, trailers or semi-trailers designed for travel on public roads, with a minimum, combined single limit of One Million Dollars (\$1,000,000) per occurrence for bodily injury, including death, and property damage.
- 9.3.4** Excess Liability Insurance over and above the Employers' Liability Commercial General Liability and Comprehensive Automobile Liability Insurance coverage, with a minimum combined single limit of Twenty Million Dollars (\$20,000,000) each occurrence/Twenty Million Dollars (\$20,000,000) general aggregate.
- 9.3.5** The Commercial General Liability Insurance, Comprehensive Automobile Insurance and Excess Public Liability Insurance policies shall name the other Party, its parent, associated and Affiliate companies and their respective directors, officers, agents, servants and employees ("Other Party Group") as additional insured. All policies shall contain provisions whereby the insurers waive all rights of subrogation in accordance with the provisions of this Agreement against the Other Party Group and provide thirty (30) Calendar Days advance written notice to the Other Party Group prior to anniversary date of cancellation or any material change in coverage or condition.
- 9.3.6** The Commercial General Liability Insurance, Comprehensive Automobile Liability Insurance and Excess Public Liability Insurance policies shall contain provisions that specify that the policies are primary and shall apply to such extent without consideration for other policies separately carried and shall state that each insured is provided coverage as though a separate policy had been issued to each, except the insurer's liability shall not be increased beyond the amount for which the insurer would have been liable had only one insured been covered. Each Party shall be responsible for its respective deductibles or retentions.
- 9.3.7** The Commercial General Liability Insurance, Comprehensive Automobile Liability Insurance and Excess Public Liability Insurance policies, if written on a Claims First Made Basis, shall be maintained in full force and effect for two (2) years after termination of this Agreement, which coverage may be in the form of tail coverage or extended reporting period coverage if agreed to by all Parties.
- 9.3.8** The requirements contained herein as to the types and limits of all insurance to be maintained by the Interconnection Customer and Transmission Owner are not intended to and shall not in any manner, limit or qualify the liabilities and obligations assumed by the Parties under this Agreement.

- 9.3.9** Within ten (10) days following the authorization to proceed with design and procurement as identified in Appendix A, and as soon as practicable after the end of each fiscal year or at the renewal of the insurance policy and in any event within ninety (90) days thereafter, Interconnection Customer and Transmission Owner shall provide certification of all insurance required in this Agreement, executed by each insurer or by an authorized representative of each insurer to the Other Party Group.
- 9.3.10** Notwithstanding the foregoing, each Party may self-insure to meet the minimum insurance requirements of Articles 9.3.2 through 9.3.8 to the extent it maintains a self-insurance program; provided that, such Party's senior secured debt is rated at investment grade or better by Standard & Poor's and that its self-insurance program meets the minimum insurance requirements of Articles 9.3.2 through 9.3.8. For any period of time that a Party's senior secured debt is unrated by Standard & Poor's or is rated at less than investment grade by Standard & Poor's, such Party shall comply with the insurance requirements applicable to it under Articles 9.3.2 through 9.3.9. In the event that a Party is permitted to self-insure pursuant to this article, it shall notify the other Party that it meets the requirements to self-insure and that its self-insurance program meets the minimum insurance requirements in a manner consistent with that specified in Article 9.3.9.
- 9.3.11** The Parties agree to report to each other in writing as soon as practical all accidents or occurrences resulting in injuries to any person, including death, and any property damage arising out of this Agreement.

ARTICLE 10 DEFAULT

- 10.1 General.** No Default shall exist where such failure to discharge an obligation (other than the payment of money) is the result of Force Majeure as defined in this Agreement or the result of an act or omission of another Party. Upon a Breach, the non-breaching Party shall give written notice of such Breach to the breaching Party. Except as provided in Article 10.2, the breaching Party shall have thirty (30) Calendar Days from receipt of the Default notice within which to cure such Breach; provided however, if such Breach is not capable of cure within thirty (30) Calendar Days, the breaching Party shall commence such cure within thirty (30) Calendar Days after notice and continuously and diligently complete such cure within ninety (90) Calendar Days from receipt of the Default notice; and, if cured within such time, the Breach specified in such notice shall cease to exist.
- 10.2 Right to Terminate.** If a Breach is not cured as provided in this article, or if a Breach is not capable of being cured within the period provided for herein, the non-breaching Party shall have the right to declare a Default and terminate this Agreement by written notice at any time until cure occurs, and be relieved of any further obligation hereunder and, whether or not that Party terminates this Agreement, to recover from the breaching Party all amounts due hereunder, plus all other damages and remedies to which it is entitled at law. The provisions of this article will survive termination of this Agreement.

ARTICLE 11

TERMINATION OF AGREEMENT

11.1 Expiration of Term. Except as otherwise specified in this Article 11, the Parties' obligations under this Agreement shall terminate at the conclusion of the term of this Agreement.

11.2 Termination. In addition to the termination provisions set forth in Article 2.2, a Party may terminate this Agreement upon the Default of another Party in accordance with this Agreement. Subject to the limitations set forth in Article 11.3, in the event of a Default, a non-Defaulting Party may terminate this Agreement only upon the later of (i) its giving of written notice of termination to the other Parties; and (ii) unless no longer required by FERC, the filing at FERC of a notice of termination for this Agreement, which filing must be accepted for filing by FERC.

11.3 Disposition of Facilities Upon Termination of Agreement.

11.3.1 Transmission Provider and Transmission Owner Obligations. Upon termination of this Agreement, unless otherwise agreed by the Parties in writing, Transmission Owner:

- (a) shall, prior to the construction and installation of any portion of the Network Upgrades, Distribution Upgrades, System Protection Facilities, and Metering Equipment and to the extent possible, cancel any pending orders of, or return, such equipment or material for such Network Upgrades, Distribution Upgrades, System Protection Facilities, and Metering Equipment;
- (b) may keep in place any portion of the Network Upgrades, Distribution Upgrades, System Protection Facilities, and Metering Equipment already constructed and installed; and,
- (c) shall perform such work as may be necessary to ensure the safety of persons and property and to preserve the integrity of the Transmission System (*e.g.*, construction demobilization to return the system to its original state, wind-up work).

11.3.2 Interconnection Customer Obligations. Upon billing by Transmission Owner, Interconnection Customer shall reimburse Transmission Owner for any costs incurred by Transmission Owner in performance of the actions required or permitted by Article 11.3.1 and for the cost of any Network Upgrades, Distribution Upgrades, System Protection Facilities, and Metering Equipment described in Appendix A. Transmission Owner and Transmission Provider shall use Reasonable Efforts to minimize costs and shall offset the amounts owed by any salvage value of facilities, if applicable. Interconnection Customer shall pay these costs pursuant to Article 7.2 of this Agreement.

11.3.3 Pre-construction or Installation. Upon termination of this Agreement and prior

to the construction and installation of any portion of the Network Upgrades, Distribution Upgrades, System Protection Facilities, and Metering Equipment, Transmission Owner may, at its option, retain any portion of such Network Upgrades, Distribution Upgrades, System Protection Facilities, and Metering Equipment not cancelled or returned in accordance with Article 11.3.1(a), in which case Transmission Owner shall be responsible for all costs associated with procuring such Network Upgrades, Distribution Upgrades, System Protection Facilities, and Metering Equipment. To the extent that Interconnection Customer has already paid Transmission Owner for any or all of such costs, Transmission Owner shall refund such amounts to Interconnection Customer. If Transmission Owner elects to not retain any portion of such facilities, Transmission Owner shall convey and make available to Interconnection Customer such facilities as soon as practicable after Interconnection Customer's payment for such facilities.

- 11.4 Survival of Rights.** Termination or expiration of this Agreement shall not relieve any Party of any of its liabilities and obligations arising hereunder prior to the date termination becomes effective, and each Party may take whatever judicial or administrative actions as appear necessary or desirable to enforce its rights hereunder. The applicable provisions of this Agreement will continue in effect after expiration, or early termination hereof to the extent necessary to provide for (A) final billings, billing adjustments and other billing procedures set forth in this Agreement; (B) the determination and enforcement of liability and indemnification obligations arising from acts or events that occurred while this Agreement was in effect; and (C) the confidentiality provisions set forth in Article 13.

ARTICLE 12 SUBCONTRACTORS

- 12.1 Subcontractors.** Nothing in this Agreement shall prevent a Party from utilizing the services of subcontractors, as it deems appropriate, to perform its obligations under this Agreement; provided, however, that each Party shall require its subcontractors to comply with all applicable terms and conditions of this Agreement in providing such services and each Party shall remain primarily liable to the other Parties for the performance of such subcontractor.

12.1.1 Responsibility of Principal. The creation of any subcontract relationship shall not relieve the hiring Party of any of its obligations under this Agreement. In accordance with the provisions of this Agreement, each Party shall be fully responsible to the other Parties for the acts or omissions of any subcontractor it hires as if no subcontract had been made. Any applicable obligation imposed by this Agreement upon a Party shall be equally binding upon, and shall be construed as having application to, any subcontractor of such Party.

12.1.2 No Third-Party Beneficiary. Except as may be specifically set forth to the contrary herein, no subcontractor or any other party is intended to be, nor will it be deemed to be, a third-party beneficiary of this Agreement.

12.1.3 No Limitation by Insurance. The obligations under this Article 12 will not be

limited in any way by any limitation of any insurance policies or coverages, including any subcontractor's insurance.

ARTICLE 13 CONFIDENTIALITY

13.1 Confidentiality. Confidential Information shall include, without limitation, all information relating to a Party's technology, research and development, business affairs, and pricing, and any information supplied by any of the Parties to another prior to the execution of this Agreement.

Information is Confidential Information only if it is clearly designated or marked in writing as confidential on the face of the document, or, if the information is conveyed orally or by inspection, if the Party providing the information orally informs the Party receiving the information that the information is confidential.

If requested by any Party, a Party shall provide in writing, the basis for asserting that the information referred to in this Article 13 warrants confidential treatment, and the requesting Party may disclose such writing to the appropriate Governmental Authority. Each Party shall be responsible for the costs associated with affording confidential treatment to its information.

13.1.1 Term. During the term of this Agreement, and for a period of two (2) years after the expiration or termination of this Agreement, except as otherwise provided in this Article 13, each Party shall hold in confidence and shall not disclose to any person Confidential Information.

13.1.2 Scope. Confidential Information shall not include information that the receiving Party can demonstrate: (1) is generally available to the public other than as a result of a disclosure by the receiving Party; (2) was in the lawful possession of the receiving Party on a non-confidential basis before receiving it from the disclosing Party; (3) was supplied to the receiving Party without restriction by a third party, who, to the knowledge of the receiving Party after due inquiry, was under no obligation to the disclosing Party to keep such information confidential; (4) was independently developed by the receiving Party without reference to Confidential Information of the disclosing Party; (5) is, or becomes, publicly known, through no wrongful act or omission of the receiving Party or Breach of this Agreement; or (6) is required, in accordance with Article 13.1.7 of the Agreement, Order of Disclosure, to be disclosed by any Governmental Authority or is otherwise required to be disclosed by law or subpoena, or is necessary in any legal proceeding establishing rights and obligations under this Agreement. Information designated as Confidential Information will no longer be deemed confidential if the Party that disclosed the information notifies the other Party that it no longer is confidential.

13.1.3 Release of Confidential Information. No Party shall release or disclose Confidential Information to any other person, except to its Affiliates (limited by

the Standards of Conduct requirements), subcontractors, employees, consultants, or to parties who may be or considering providing financing to or equity participation with Interconnection Customer, or to potential purchasers or assignees of Interconnection Customer, on a need-to-know basis in connection with this Agreement, unless such person has first been advised of the confidentiality provisions of this Article 13 and has agreed to comply with such provisions. Notwithstanding the foregoing, a Party providing Confidential Information to any person shall remain primarily responsible for any release of Confidential Information in contravention of this Article 13.

13.1.4 Rights. Each Party retains all rights, title, and interest in the Confidential Information that each Party discloses to another Party. The disclosure by any Party to another Party of Confidential Information shall not be deemed a waiver by the disclosing Party or any other person or entity of the right to protect the Confidential Information from public disclosure.

13.1.5 No Warranties. By providing Confidential Information, no Party makes any warranties or representations as to its accuracy or completeness. In addition, by supplying Confidential Information, no Party obligates itself to provide any particular information or Confidential Information to another Party nor to enter into any further agreements or proceed with any other relationship or joint venture.

13.1.6 Standard of Care. Each Party shall use at least the same standard of care to protect Confidential Information it receives as it uses to protect its own Confidential Information from unauthorized disclosure, publication or dissemination. Each Party may use Confidential Information solely to fulfill its obligations to another Party under this Agreement or its regulatory requirements.

13.1.7 Order of Disclosure. If a court or a Governmental Authority or entity with the right, power, and authority to do so requests or requires a Party, by subpoena, oral deposition, interrogatories, requests for production of documents, administrative order, or otherwise, to disclose Confidential Information, that Party shall provide the other Parties with prompt notice of such request(s) or requirement(s) so that the other Parties may seek an appropriate protective order or waive compliance with the terms of this Agreement. Notwithstanding the absence of a protective order or waiver, the Party may disclose such Confidential Information which, in the opinion of its counsel, the Party is legally compelled to disclose. Each Party will use Reasonable Efforts to obtain reliable assurance that confidential treatment will be accorded any Confidential Information so furnished.

13.1.8 Termination of Agreement. Upon termination of this Agreement for any reason, each Party shall, within ten (10) Calendar Days of receipt of a written request from another Party, use Reasonable Efforts to destroy, erase, or delete (with such destruction, erasure, and deletion certified in writing to the other Party) or return to the other Party, without retaining copies thereof, any and all written or electronic Confidential Information received from the other Party.

13.1.9 Remedies. In the instance where Transmission Owner is a Federal Power Agency, as specified in the opening paragraph of this Agreement, then this section 13.1.9 shall not apply to Transmission Owner. The Parties agree that monetary damages would be inadequate to compensate a Party for another Party's Breach of its obligations under this Article 13. Each Party accordingly agrees that the other Parties shall be entitled to equitable relief, by way of injunction or otherwise, if the first Party Breaches or threatens to Breach its obligations under this Article 13, which equitable relief shall be granted without bond or proof of damages, and the receiving Party shall not plead in defense that there would be an adequate remedy at law. Such remedy shall not be deemed an exclusive remedy for the Breach of this Article 13, but shall be in addition to all other remedies available at law. The Parties further acknowledge and agree that the covenants contained herein are necessary for the protection of legitimate business interests and are reasonable in scope. No Party, however, shall be liable for indirect, incidental, or consequential or punitive damages of any nature or kind resulting from or arising in connection with this Article 13.

13.1.10 Disclosure to FERC, its Staff, or a State. Notwithstanding anything in this Article 13 to the contrary, and pursuant to 18 C.F.R. section 1b.20, if FERC or its staff, during the course of an investigation or otherwise, requests information from one of the Parties that is otherwise required to be maintained in confidence pursuant to this Agreement, the Party shall provide the requested information to FERC or its staff, within the time provided for in the request for information. In providing the information to FERC or its staff, the Party must, consistent with 18 C.F.R. section 388.112, request that the information be treated as confidential and non-public by FERC and its staff and that the information be withheld from public disclosure. Parties are prohibited from notifying another Party to this Agreement prior to the release of the Confidential Information to FERC or its staff. The Party shall notify the other Parties to the Agreement when it is notified by FERC or its staff that a request to release Confidential Information has been received by FERC, at which time any of the Parties may respond before such information would be made public, pursuant to 18 C.F.R. section 388.112. Requests from a state regulatory body conducting a confidential investigation shall be treated in a similar manner, if consistent with the applicable state rules and regulations.

13.1.11 Subject to the exception in Article 13.1.10, any information that a Party claims is competitively sensitive, commercial or financial information under this Agreement (“Confidential Information”) shall not be disclosed by another Party to any person not employed or retained by the other Party, except to the extent disclosure is (i) required by law; (ii) reasonably deemed by the disclosing Party to be required to be disclosed in connection with a dispute between or among the Parties, or the defense of litigation or dispute; (iii) otherwise permitted by consent of the other Party, such consent not to be unreasonably withheld; or (iv) necessary to fulfill its obligations under this Agreement or as a transmission service provider or a Control Area operator including disclosing the Confidential Information to an Regional Transmission Organization or Independent System Operator or to a regional or national reliability organization. The Party asserting confidentiality

shall notify the other Party in writing of the information it claims is confidential. Prior to any disclosures of the other Party's Confidential Information under this subparagraph, or if any third party or Governmental Authority makes any request or demand for any of the information described in this subparagraph, the disclosing Party agrees to promptly notify the other Party in writing and agrees to assert confidentiality and cooperate with the other Party in seeking to protect the Confidential Information from public disclosure by confidentiality agreement, protective order or other reasonable measures.

13.1.12 This provision shall not apply to any information that was or is hereafter in the public domain (except as a result of a Breach of this provision).

ARTICLE 14 INFORMATION ACCESS AND AUDIT RIGHTS

14.1 Information Access. Each Party shall make available to the other Parties information necessary to verify the costs incurred by the other Parties for which the requesting Party is responsible under this Agreement and carry out obligations and responsibilities under this Agreement, provided that the Parties shall not use such information for purposes other than those set forth in this Article 14.1 and to enforce their rights under this Agreement.

14.2 Audit Rights. Subject to the requirements of confidentiality under Article 13 of this Agreement, the accounts and records related to the design, engineering, procurement, and construction of the Network Upgrades, Distribution Upgrades, System Protection Facilities, and Metering Equipment shall be subject to audit during the period of this Agreement and for a period of twenty-four (24) months following Transmission Owner's issuance of a final invoice in accordance with Article 7.2. Interconnection Customer at its expense shall have the right, during normal business hours, and upon prior reasonable notice to the other Parties, to audit such accounts and records. Any audit authorized by this Article 14.2 shall be performed at the offices where such accounts and records are maintained and shall be limited to those portions of such accounts and records that relate to obligations under this Agreement.

ARTICLE 15 DISPUTES

15.1 Submission. In the event any Party has a dispute, or asserts a claim, that arises out of or in connection with this Agreement or its performance, the Parties agree to resolve such dispute using the dispute resolution procedures of the Tariff.

ARTICLE 16 NOTICES

16.1 General. Any notice, demand or request required or permitted to be given by a Party to another Party and any instrument required or permitted to be tendered or delivered by a Party in writing to another Party may be so given, tendered or delivered, as the case may be, by depositing the same with the United States Postal Service with postage prepaid, for

transmission by certified or registered mail, addressed to the Parties, or personally delivered to the Parties, at the address set out below:

To Transmission Provider:

Tessie Kentner, Attorney
Southwest Power Pool, Inc.
201 Worthen Drive
Little Rock, AR 72223-4936
Phone: (501) 688-1782
Email: tkentner@spp.org

To Transmission Owner:

Manager, Transmission Business Relations
Xcel Energy Services Inc.
414 Nicollet Mall
Minneapolis, MN 55401
Phone: (612) 330-6773 or (800) 328-8226 ext. 0
Email: mark.c.moeller@xcelenergy.com

To Interconnection Customer:

Thomas Coté
Manager
AEM Wind LLC
645 North Michigan, Suite 980
Chicago, IL 60611
Phone: (312) 283-3400
Email: cote@akuoenergy.com

16.2 Billings and Payments. Billings and payments shall be sent to the addresses shown in Article 16.2 unless otherwise agreed to by the Parties.

To Transmission Provider:

Supervisor of Transmission Settlements
Southwest Power Pool, Inc.
201 Worthen Drive
Little Rock, AR 72223-4936

To Transmission Owner:

Manager, Transmission Business Relations
Xcel Energy Services Inc.
414 Nicollet Mall
Minneapolis, MN 55401
Phone: (612) 330-6773 or (800) 328-8226 ext. 0

Facsimile: (612) 330-6357

To Interconnection Customer:

Thomas Cote
AEM Wind LLC
645 North Michigan, Suite 980
Chicago, IL 60611
Phone: (312) 283-3400
Email: cote@akuoenergy.com

- 16.3 DUNS #.** If Transmission Owner and Interconnection Customer have not obtained DUNS numbers by the time this Agreement is executed, Transmission Owner and Interconnection Customer will forward their DUNS numbers within five (5) business days of having obtained such numbers to Transmission Provider by facsimile telephone or email to the fax number or email set out in Article 16.1:

Transmission Owner

Southwestern Public Service Company
DUNS Number: 007369713
Facsimile: 612-330-6357
Email: mark.c.moeller@xcelenergy.com

Interconnection Customer

AEM Wind LLC
DUNS Number: 942713327
Phone Number: (312) 283-3400
Email: cote@akuoenergy.com

- 16.4 Notification of In-Service Date.** Transmission Owner will serve to Transmission Provider a copy of Appendix B as forwarded to Interconnection Customer on the same day to the address shown in Article 16.1, and by facsimile telephone to the numbers set out below:

To Transmission Provider:

Tessie Kentner, Attorney
Southwest Power Pool, Inc.
201 Worthen Drive
Little Rock, AR 72223-4936
Phone: (501) 688-1782
Facsimile: (501) 482-2022
Email: tkentner@spp.org

**ARTICLE 17
MISCELLANEOUS**

- 17.1 Waiver.** Except as otherwise provided for in this Agreement, the failure of any Party to comply with any obligation, covenant, agreement, or condition herein may be waived by the Parties entitled to the benefits thereof only by a written instrument signed by the Parties granting such waiver. Any waiver at any time by a Party of its rights with respect to a Default under this Agreement, or with respect to any other matters arising in connection with this Agreement, shall not be deemed a waiver or continuing waiver with respect to any subsequent Default or other matter.
- 17.2 Governing Law.** The validity, interpretation and performance of this Agreement and each of its provisions shall be governed by the laws of the state where the Network Upgrades, Distribution Upgrades, System Protection Facilities, and Metering Equipment referenced in Appendix A are located without regard to its conflicts of law principles.
- 17.3 Headings Not to Affect Meaning.** The descriptive headings of the various Sections and Articles of this Agreement have been inserted for convenience of reference only and shall in no way modify or restrict any of the terms and provisions hereof.
- 17.4 Amendments and Rights Under the Federal Power Act.** Transmission Provider shall have the right to make an unilateral filing with FERC to modify this Agreement with respect to any rates, terms and conditions, charges, classifications of service, rule or regulation under Section 205 or any other applicable provision of the Federal Power Act and FERC's rules and regulations thereunder, and Transmission Owner and Interconnection Customer shall have the right to make a unilateral filing with FERC to modify this Agreement pursuant to Section 206 or any other applicable provision of the Federal Power Act and FERC's rules and regulations thereunder; provided, however, that each Party shall have the right to protest any such filing and to participate fully in any proceeding before FERC in which such modifications may be considered. Nothing in this Agreement shall limit the rights of the Parties or of FERC under Sections 205 or 206 of the Federal Power Act and FERC's rules and regulations thereunder, except to the extent that the Parties otherwise mutually agree as provided herein.
- 17.5 Entire Agreement.** This Agreement, together with all the exhibits, constitutes the final and entire written agreement among the Parties hereto with reference to the subject matter hereof, and is a complete and exclusive statement of those terms and conditions and supersedes all prior negotiations, representations or agreements, either written or oral, with respect to the specific subject matter of this Agreement. No change or modification as to any of the provisions hereof shall be binding on any Party unless reduced to writing and approved by the duly authorized officer or agent of Interconnection Customer, Transmission Owner, and Transmission Provider.
- 17.6 Counterparts.** This Agreement may be executed in any number of counterparts, and each executed counterpart shall have the same force and effect as an original instrument.
- 17.7 Binding Effect.** This Agreement and the rights and obligations hereof, shall be binding upon and shall inure to the benefit of the Parties hereto and their successors and assigns. No person or party shall have any rights, benefits or interests, direct or indirect, arising from this Agreement except the Parties hereto, their successors and authorized assigns.

The Parties expressly disclaim any intent to create any rights in any person or party as a third party beneficiary to this Agreement.

- 17.8 Conflicts.** In the event of a conflict between the body of this Agreement and any attachment, appendix or exhibit hereto, the terms and provisions of the body of this Agreement shall prevail and be deemed to be the final intent of the Parties.
- 17.9 Regulatory Requirements.** Each Party's obligations under this Agreement shall be subject to its receipt of any required approval or certificate from one or more Governmental Authorities in the form and substance satisfactory to the receiving Party, or the Party making any required filings with, or providing notice to, such Governmental Authorities, and the expiration of any time period associated therewith. Each Party shall in good faith seek these other approvals as soon as is reasonably practicable.
- 17.10 No Right to Transmission Service.** This Agreement does not in and of itself convey transmission service rights to Interconnection Customer or Transmission Owner; and nothing contained herein is intended to provide any obligation on the part of Transmission Provider to grant transmission service pursuant to the Tariff to the other Parties.

ARTICLE 18 REPRESENTATIONS AND WARRANTIES

- 18.1 General.** Each Party hereby represents, warrants and covenants as follows with these representations, warranties, and covenants effective as to the Party during the full time this Agreement is effective:
- 18.1.1 Good Standing.** Such Party is duly organized or formed, as applicable, validity existing and in good standing under the laws of its state of organization or formation, and is in good standing under the laws of the respective state(s) of their organization as stated in the preamble of this Agreement.
- 18.1.2 Authority.** Such Party has the right, power and authority to enter into this Agreement, to become a party hereto and to perform its obligations hereunder, and this Agreement is a legal, valid and binding obligation of such Party, enforceable against such Party in accordance with its terms.
- 18.1.3 No Conflict.** The execution, delivery and performance of this Agreement does not violate or conflict with the organizational or formation documents, or bylaws or operating agreement, of such Party, or any judgment, license, permit or order or material agreement or instrument applicable to or binding upon such Party or any of its assets.
- 18.1.4 Consent and Approval.** That it has sought or obtained, or, in accordance with this Agreement will seek or obtain, each consent, approval, authorization or order of, or acceptance of a filing with, or notice to, any Governmental Authority with jurisdiction concerning this Agreement, in connection with the execution, delivery

and performance of this Agreement.

18.1.5 Solvency. That such Party is financially solvent.

[Remainder of this page intentionally left blank]

[Signatures appear on the following page]

IN WITNESS WHEREOF, the Parties have executed this Agreement in multiple originals, each of which shall constitute and be an original Agreement among the Parties.

SOUTHWEST POWER POOL, INC.

By: /s/ Carl Monroe

Name: Carl Monroe

Title: EVP & COO

Date: 09/12/2016

SOUTHWESTERN PUBLIC SERVICE COMPANY

By: /s/ I. R. Benson

Name: Ian R. Benson

Title: Director, Transmission Planning & Business Relations, as agent for Southwestern Public Service Co.

Date: 8/22/2016

AEM WIND LLC

By: /s/ Thomas Cote

Name: Thomas Cote

Title: Manager

Date: August 25, 2016

Facilities Construction Agreement

APPENDIX A

NETWORK UPGRADES, DISTRIBUTION UPGRADES, SYSTEM PROTECTION FACILITIES, METERING EQUIPMENT, COST ESTIMATES AND RESPONSIBILITY, TRANSMISSION CREDITS, CONSTRUCTION SCHEDULE AND MONTHLY PAYMENT SCHEDULE

This Appendix A is a part of the Facilities Construction Agreement between Interconnection Customer, Transmission Owner, and Transmission Provider.

1.1 Network Upgrades to be installed by Transmission Owner. All additions, modifications, and upgrades to the Transmission System.

- None

1.2 Distribution Upgrades to be installed by Transmission Owner. All additions, modifications, and upgrades to the Distribution System at or beyond the Point of Interconnection to facilitate interconnection of the Generating Facility and render the transmission service necessary to affect Interconnection Customer's wholesale sale of electricity in interstate commerce. Distribution Upgrades do not include Interconnection Facilities.

- None

1.3 System Protection Facilities to be installed by Transmission Owner and Interconnection Customer. All equipment, including necessary protection signal communications equipment, required to protect (1) the Transmission System or other delivery systems or other generating systems from faults or other electrical disturbances occurring at the Generating Facility and (2) the Generating Facility from faults or other electrical system disturbances occurring on the Transmission System or on other delivery systems or other generating systems to which the Transmission System is directly connected.

1.3.1 Transmission Owner Responsibilities

- None

1.4 Metering Equipment to be installed by Transmission Owner and Interconnection Customer. All metering equipment installed or to be installed at the Generating Facility pursuant to this Agreement at the metering points, including but not limited to instrument transformers, MWh-meters, data acquisition equipment, remote terminal unit, communications equipment, and phone lines.

1.4.1 Transmission Owner Responsibilities

- Metering and Communications Requirements:
 - Revenue Metering \$2,000

- Interconnection Metering (Upgrading of metering at three LCEC delivery points for bidirectional measuring) \$ 450

Transmission Owner Metering Equipment Estimated Cost **\$ 2,450**

1.4.2 Interconnection Customer Responsibilities

- Communications – the Interconnection Customer is required to provide a dial up telephone circuit or provide internet access for remote interrogation of the revenue meter.
- Instrument transformers - Interconnection Customer to install, own, and maintain.

1.5 Shared Network Upgrades.

- None

1.6 Total Interconnection Costs. The total cost for the Network Upgrades, Distribution Upgrades, System Protection Facilities, Metering Equipment and Shared Network Upgrades is estimated at \$2,450.

1.7 Transmission Credits. See Article 3.2.2 of the Agreement.

The portion of the Network Upgrades that could be subject to the transmission service credits described in Article 3.2.2 of this Agreement is estimated at \$0 which will be adjusted for actual costs and expenses incurred in accordance with Article 3.2.2.

1.8 First Equipment Order (including permitting).

1.8.1. Permitting And Land Rights - Transmission Owner Network Upgrades, Distribution Upgrades, System Protection Facilities, and/or Metering Equipment

1.9 Construction Schedule. Construction of the Network Upgrades, System Protection Facilities, and/or Metering Equipment is scheduled as follows:

Table 1: Construction Activities

MILESTONE NUMBER	DESCRIPTION	Party	DATE
1	Provide authorization to proceed with design and procurement of Metering Equipment listed in Appendix A, Item 1.4.	Interconnection Customer	10/1/2016
2	Provide Security per Article 3.2.3 equal to the amount pursuant to the amount found in Table 2, Appendix A.	Interconnection Customer	10/1/2016
3	Provide authorization to proceed with construction of Metering Equipment listed in Appendix A, Item 1.4	Interconnection Customer	05/01/2017
4	Transmission Owner to complete installation of Metering Equipment	Transmission Owner	06/01/2017
5	Commercial Operation Date of Generating Facility.	Interconnection Customer	9/30/2017
6	Final Invoice (per Sec. 7.2) True-up total Transmission Owner Costs for Metering Equipment.	Transmission Owner	12/30/2017

1.10 Payment Schedule.

1.10.1 Timing of and Adjustments to Interconnection Customer's Payments and Security. The following payment schedule is based upon engineering estimates of the cost of the project. Further adjustments of Interconnection Customer's Payment schedule may be necessary as bids are awarded for equipment, materials, and services required for construction of this transmission line and substation. Transmission Owner shall provide 45 days' written notice of any requested change in Customer's Payment Schedule, along with support for need for change.

1.10.2 Monthly Payment Schedule. The Interconnection Customer's payment schedule will conform to the schedule set forth in Appendix A, Table 2, below.

Table 2: Interconnection Customer's Payment/Security Obligations for Transmission Owner Network Upgrades, Distribution Upgrades, System Protection Facilities, and/or Metering Equipment. (see above)

MILESTONE NUMBER	DESCRIPTION	AMOUNT	DATE
1	Payment 1	\$2,450	10/1/2016

1.11 Permits, Licenses and Authorizations.

To be determined during project design phase.

Facilities Construction Agreement

Exhibit A1 – One-line Diagram of Transmission Owner’s Metering Equipment Facility Construction

SCADA Communications: To meet its communications obligations, the Interconnection Customer or its Host Distribution Provider system shall be responsible for making arrangements with appropriate communications providers to provide SCADA and accumulator data to the SPS Control Center.

Western Farmers Electric Cooperative (“WFEC”) will provide the required data to SPP through the ICCP link. Data required is:

MW output

MVAR output

Breaker status

Number of turbines available

Potential MW output of farm

Active curtailment set point

MWH output accumulator

The following communications schematic diagram, which includes communication equipment information for the Interconnection Customer, SPP, SPS, and Host Distribution Provider, is provided to assist the Parties.

A schematic outlining the proposed communications is provided below.

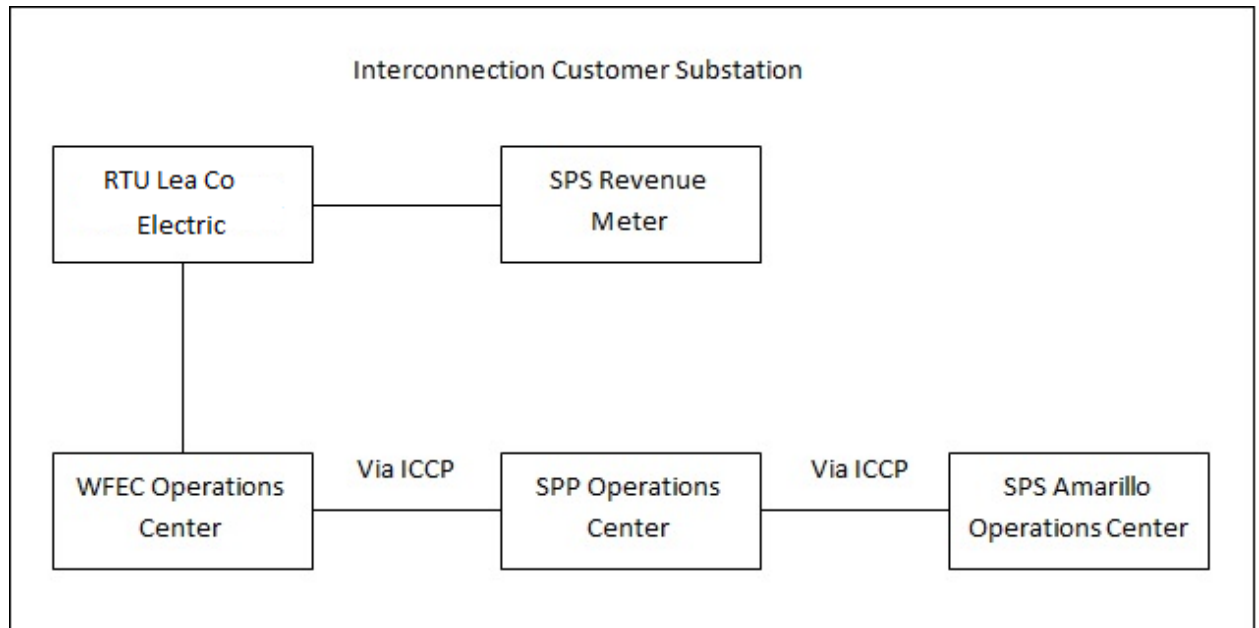
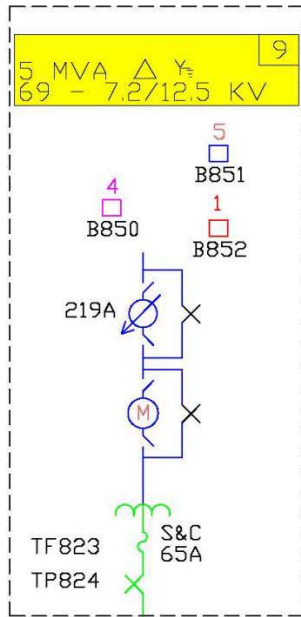
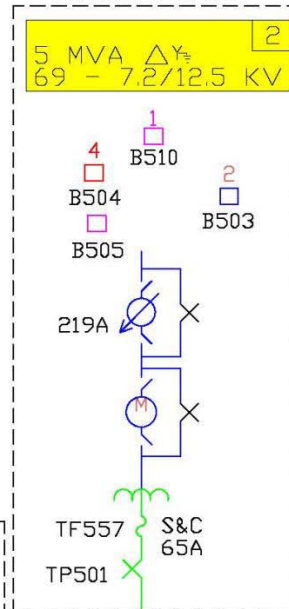

Exhibit A2 – Point of Interconnection Substation

Crossroads Sub



Tatum Sub



18 Miles
4/0

Sterling Wind
30 MW

8 Miles

Tatum Switch

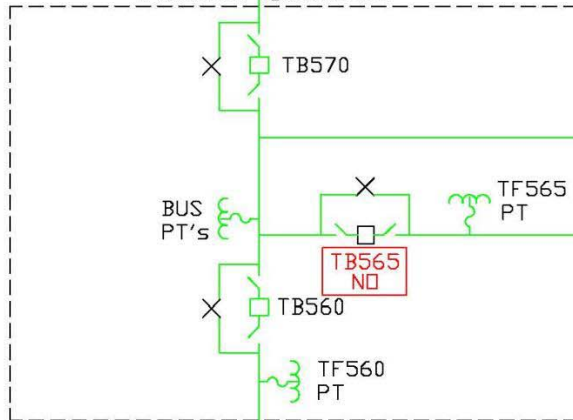

11.0 MILES

4/0 ACSR

7.0 MILES
2/0 ACSR

Exhibit A3 - AEM Wind LLC Substation

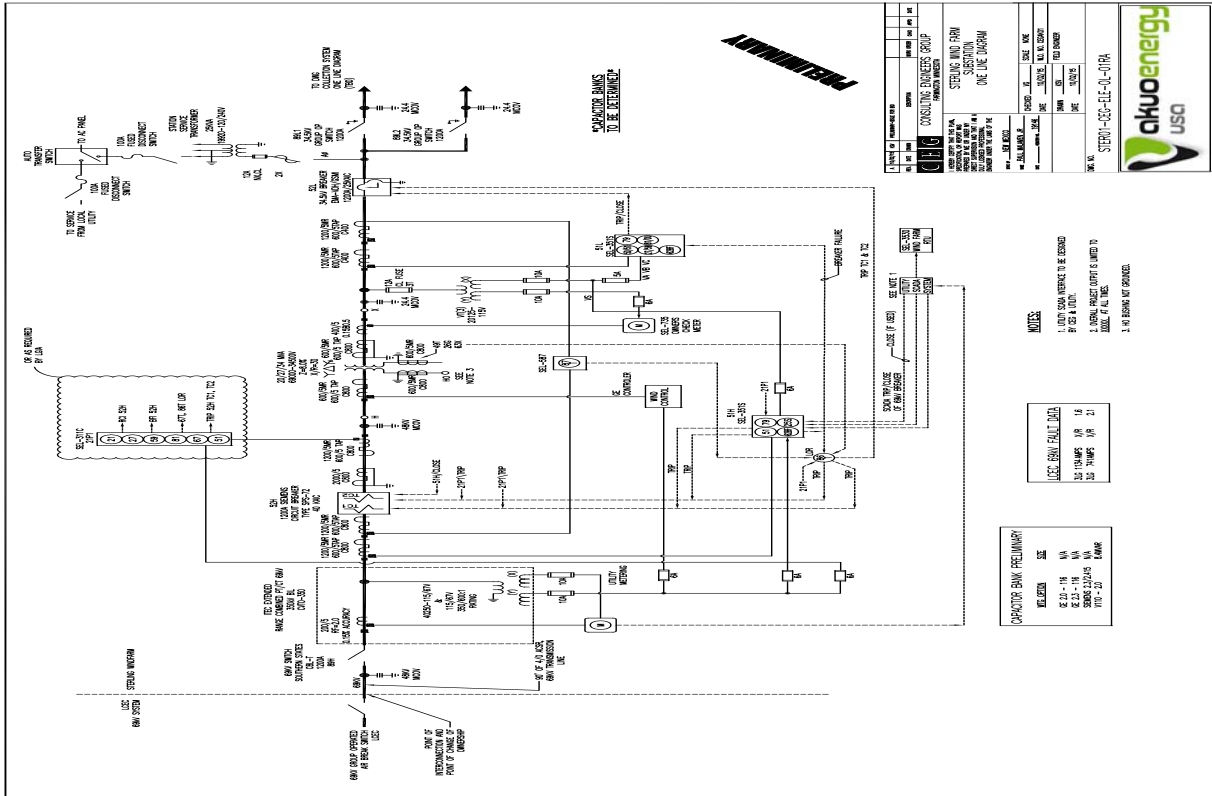

Facilities Construction Agreement
APPENDIX B
NOTIFICATION OF COMPLETED CONSTRUCTION

This Appendix B is a part of the Facilities Construction Agreement among Interconnection Customer, Transmission Owner, and Transmission Provider. When Transmission Owner has completed construction of the Network Upgrades, Distribution Upgrades, System Protection Facilities, and/or Metering Equipment, Transmission Owner shall send notice to Interconnection Customer and the Transmission Provider, in substantially the following form:

[Date]

Tessie Kentner, Attorney
Southwest Power Pool, Inc.
201 Worthen Drive
Little Rock, AR 72223-4936
Phone: (501) 688-1782
Facsimile: (501) 482-2022
Email: tkentner@spp.org

Thomas Coté, Manager
[AEM](#) Wind LLC
645 North Michigan, Suite 980
Chicago, IL 60611
Phone: (312) 283-3400
Facsimile: (312) 283-3419
Email: cote@akuoenergy.com

Re: Completion of Construction of Facilities

Dear Mrs. Kentner and Mr. Coté:

This letter is sent pursuant to the Facilities Construction Agreement among Southwestern Public Service Company (“Transmission Owner”), AEM Wind LLC (“Interconnection Customer”), and the Southwest Power Pool, Inc., dated _____, 20__.

On [Date], Transmission Owner completed to its satisfaction all work on the Metering Equipment required to facilitate the safe and reliable interconnection and operation of Interconnection Customer’s Generating Facility. Transmission Owner confirms that the Metering Equipment is in place.

Thank you.

Manager, Transmission Business Relations
Xcel Energy Services Inc.
414 Nicollet Mall
Minneapolis, MN 55401

FERC rendition of the electronically filed tariff records in Docket No. ER16-02634-000

Filing Data:

CID: C000771

Filing Title: 3247 AEM Wind/SPS Facilities Construction Agreement

Company Filing Identifier: 1471

Type of Filing Code: 10

Associated Filing Identifier:

Tariff Title: Service Agreements Tariff

Tariff ID: 16

Payment Confirmation:

Suspension Motion:

Tariff Record Data:

Record Content Description, Tariff Record Title, Record Version Number, Option Code:

3247 AEM Wind.SPS ASFCA, 3247 AEM Wind/SPS Facilities Construction Agreement, 0.0.0, A

Record Narrative Name:

Tariff Record ID: 445

Tariff Record Collation Value: 1000520 Tariff Record Parent Identifier: 0

Proposed Date: 2016-09-12

Priority Order: 500

Record Change Type: NEW

Record Content Type: 2

Associated Filing Identifier:

This is a PDF section and we cannot render PDF in a RTF document.

Document Content(s)

1471-a0327773-0009-479e-b3ef-a44a38ef72a6.PDF.....1-8

1471-a9378acc-6ce7-49c5-8d0a-542390da5f68.PDF.....9-52

FERC GENERATED TARIFF FILING.RTF.....53-53