



PJM Interconnection  
2750 Monroe Blvd.  
Audubon, PA 19403

Robert V. Eckenrod  
Senior Counsel  
610.666.3184 | fax 610.666.8211  
robert.eckenrod@pjm.com

February 12, 2015

Honorable Kimberly D. Bose  
Secretary  
Federal Energy Regulatory Commission  
888 First Street, N.E., Room 1A  
Washington, D.C. 20426

**Re: PJM Interconnection, L.L.C., Docket No. ER15-\_\_\_\_-000  
Queue Position #Y2-055 – Service Agreement No. 4093**

Dear Ms. Bose:

Pursuant to section 205 of the Federal Power Act (“FPA”),<sup>1</sup> and part 35 of the regulations of the Federal Energy Regulatory Commission (“Commission” or “FERC”),<sup>2</sup> PJM Interconnection, L.L.C. (“PJM”) submits for filing an executed Wholesale Market Participation Agreement (“WMPA” or “Agreement”) entered into among PJM, United Refining Company (“Wholesale Market Participant” or “URC”) and Pennsylvania Electric Company (“Transmission Owner” or “Penelec”), executed on January 14, 2015. PJM is submitting this Agreement for filing because URC intends to engage in wholesale sales in the PJM markets from a generating facility connected to Penelec’s distribution facilities. PJM requests an effective date of January 14, 2015 for this WMPA, which is designated as Original Service Agreement No. 4093<sup>3</sup> and is attached to this filing. The WMPA will facilitate URC’s intent to engage in jurisdictional wholesale transactions in the PJM markets, which will originate over non-jurisdictional distribution facilities.

---

<sup>1</sup> 16 U.S.C. § 824d (2006).

<sup>2</sup> 18 C.F.R. Part 35 (2010).

<sup>3</sup> Because the WMPA being electronically filed with this transmittal letter contains electronic signatures and not the original signatures of the parties, a copy of the sheet(s) containing the original signatures is included as Attachment A to this transmittal letter.

Honorable Kimberly D. Bose  
February 12, 2015  
Page 2

## **I. Background**

On February 22, 2006, the Commission issued the GSG Order,<sup>4</sup> which held that the interconnection of a generator to non-jurisdictional distribution facilities is not, in and of itself, action regulated by the FPA.<sup>5</sup> The Commission further stated that the distribution facilities become FERC jurisdictional once a wholesale transaction occurs on the system. This action would, therefore, render any subsequent interconnection to the relevant distribution facilities Commission jurisdictional.

PJM routinely receives requests from generation developers seeking to interconnect at a distribution level, in order to participate in sales to the PJM markets. Where the relevant facilities are non-jurisdictional (because there exists no previously interconnected generator engaging in wholesale transactions), and, in light of the GSG Order, PJM developed the WMPA as a contractual means to address these requests and provide to all affected parties a process to enable PJM to properly track and study this category of generator interconnection, as well as to facilitate the generator's participation in PJM's organized wholesale markets. The WMPA also serves to establish important revenue and (if necessary) operational metering requirements in order to give PJM visibility to pay the generator for output and for potential operational security requirements. In rare instances, a non-jurisdictional interconnection could impact the integrated transmission system. The WMPA process allows PJM to ensure that this contingency is studied and corrected, if necessary.

At this time FERC has previously accepted a number of WMPAs in earlier filings involving other participants. The instant filing is in the same form as the earlier submittals.<sup>6</sup>

## **II. This WMPA Establishes Reasonable Requirements to Enable Wholesale Transactions Subject to the Commission's Jurisdiction**

The instant WMPA is filed pursuant to the Commission's jurisdiction under Section 205 of the FPA and the Commission's independent jurisdictional authority over wholesale sales of electric energy and related products in PJM's markets. These transactions plainly constitute regulated wholesale transactions pursuant to Section 201(b)(1) of the FPA.<sup>7</sup> Under the FPA, the Commission has broad jurisdiction to regulate the wholesale sale of electricity in interstate

---

<sup>4</sup> See *PJM Interconnection, L.L.C.*, 114 FERC ¶ 61,191 (2006) ("GSG Order").

<sup>5</sup> See *PJM Interconnection, L.L.C.*, 116 FERC ¶ 61,102 (2006) (Order Denying Rehearing and Clarification and noting the FPA denies the Commission jurisdiction "over facilities used in local distribution"). The Order denies the requests for rehearing filed on behalf of GSG, the American Wind Energy Association and Mendota Hills, LLC.

<sup>6</sup> See *PJM Interconnection, L.L.C.*, Docket Nos. ER12-2594-000; ER12-2610-000; ER12-2550-000; ER12-2409-000; ER12-2294-000; ER12-2421-000; ER12-2416-000; ER12-2174-000; ER12-2293-000; ER12-2155-000; ER12-2126-000; ER12-2128-000 and ER12-2143-000.

<sup>7</sup> Specifically, the FPA applies "to the transmission of electric energy in interstate commerce and to the sale of electric energy at wholesale in interstate commerce." 16 U.S.C. § 824(b)(1) (*emphasis added*).

Honorable Kimberly D. Bose

February 12, 2015

Page 3

commerce.<sup>8</sup> As noted above, the transactions will originate over facilities that are not Commission jurisdictional, namely the distribution facilities. In such circumstances, the Commission parses the transaction so as to apply its jurisdiction to only those aspects of the transaction that are Commission jurisdictional. For example, the Commission applies this logic to determine jurisdiction over an interconnection on a facility used for both retail and wholesale transactions as discussed in Order No. 2003,<sup>9</sup> by segregating the jurisdictional transaction from the retail sales. The Commission noted: “[W]here the ‘distribution’ facilities have a dual use, *i.e.*, the facilities are used for both wholesale sales and retail sales, the Final Rule applies to interconnections to these facilities only for the purpose of making sales of electric energy for resale in interstate commerce.”<sup>10</sup> The Commission bifurcates the use of the facility and applies its jurisdiction only to the applicable transaction, the wholesale sale. Here, the generator’s use of, and taking of service over, the distribution facilities does not diminish the Commission’s independent jurisdiction to regulate the generator’s sale of energy and related products in PJM’s organized wholesale markets.

This logic is consistently applied in other areas of Commission jurisdiction as well. For example, the Commission applied similar reasoning when it determined it has jurisdiction to require transmission service over non-jurisdictional local distribution facilities in *Tex-La Electric Cooperative of Texas, Inc.*<sup>11</sup> The Commission noted that it retained authority to order transmission service pursuant to Section 211 of the FPA regardless of any local distribution function of the facilities involved and “. . . transmission *services* may encompass the use of *facilities* that in other contexts would be classified as distribution facilities.”<sup>12</sup> Similarly, in *Laguna Irrigation District*, the Commission noted that wholesale customers should be allowed the protection of Section 210 of the FPA based merely on the label attached to the facilities to which they interconnect.<sup>13</sup>

Accordingly, since the WMPA addresses the terms and conditions necessary for the generator to make wholesale sales into the PJM markets, PJM applies the same reasoning as

---

<sup>8</sup> See 16 U.S.C. § 824(d) (“Unless the Commission otherwise orders, no change shall be made by any public utility in any such rates, charges, classification, or service, or in any rule, regulation, or contract relating thereto, except after sixty days’ notice to the Commission and to the public”).

<sup>9</sup> See *Detroit Edison Co. v. FERC*, 334 F.3d 48, 51 (D.C. Cir. 2003) (explaining that the Commission has jurisdiction “over all wholesale service,” including wholesale transactions that occur over “local distribution” facilities); See also, *PJM Interconnection, L.L.C.*, 116 FERC ¶ 61,102 (July 31, 2006) at P 22. (“Because no wholesale transaction is being conducted on ComEd’s distribution facilities, we find there is no Commission-jurisdictional use of the facilities . . . .” Hence, a wholesale transaction would be a jurisdictional use.).

<sup>10</sup> Order No. 2003 at P804; *Accord* Order No. 2003-C at P 53.

<sup>11</sup> *Tex-La Electric Cooperative of Texas, Inc.*, 67 FERC ¶ 61,019, *final order*, 69 FERC ¶ 61,269 (1994)(“*Tex-La Electric Cooperative*”); See *Laguna Irrigation District*, 95 FERC ¶ 61,305 (2001), *aff’d sub nom. Pacific Gas & Electric Co. v. FERC*, 44 Fed. Appx. 170 (9<sup>th</sup> Cir. 2002) (“*Laguna Irrigation*”).

<sup>12</sup> *Tex-La Electric Cooperative of Texas, Inc.*, 67 FERC ¶ at 61,056 n. 36 (emphasis in original).

<sup>13</sup> *Laguna Irrigation, supra*.

Honorable Kimberly D. Bose  
February 12, 2015  
Page 4

detailed above and believes that an agreement enabling such sales (the WMPA) similarly falls within the Commission's jurisdiction.

Should the Commission disagree and decide not to exercise its jurisdiction over the WMPA, PJM will, nonetheless, require execution of the WMPA by similarly-situated generators and transmission owners as a matter of contract. The matters addressed by the WMPA are essential to preserve the continued integrity of PJM's functions as a grid operator and market administrator; and, as such, are properly deemed reasonable conditions of entry, like other RTO membership requirements, for a generator electing to participate in PJM's voluntary markets.

### **III. The WMPA Applies to Wholesale Sales Only**

PJM submitted the WMPA for filing because the WMPA is a form of agreement not presently contained in either the PJM Open Access Transmission Tariff ("PJM Tariff") or the PJM Operating Agreement. The WMPA applies only to wholesale transactions and is not intended to govern the actual physical interconnection of a generating facility to the distribution system. Therefore, it is immaterial whether the WMPA concerns a new interconnection to a distribution system or a pre-existing interconnection on a distribution system where the pre-existing generator subsequently elects to participate in the PJM markets. The WMPA will be initiated for the purpose of facilitating the wholesale sale and not the interconnection. To date, generator market participants connecting to the distribution system have been receptive to the use of the WMPA as a means to facilitate future sales into the PJM markets and to support the state interconnection processes as well. Further, the WMPA allows a vehicle for PJM to examine the potential reliability impacts the interconnection may have on the grid.

As the GSG Order directs,<sup>14</sup> interconnection to the distribution system is not FERC jurisdictional until wholesale sales begin on the system. Hence, the PJM Tariff would not apply to govern the terms and conditions of the physical interconnection, including the attachment of facilities and terms of use and charges for distribution service needed to afford the generator access to the PJM Transmission System. Again, PJM's interest is to ensure sufficient visibility and, where necessary, control over generation that is participating as a Market Seller under the PJM Operating Agreement.<sup>15</sup>

### **IV. The WMPA Differs from the ISA in Numerous Important Aspects**

The WMPA is designed to have a similar format to the PJM Interconnection Service Agreement ("ISA") in order to provide a manageable and familiar document for the participants. Unlike the ISA, however, the WMPA does not address matters involving the actual physical interconnection of the generator to the distribution system or any terms, conditions or charges related to any service provided by the distribution system to the generator. The WMPA contains many provisions also typically found in an ISA that govern the relationship between the

---

<sup>14</sup> See GSG Order at P 14.

<sup>15</sup> See Amended and Restated Operating Agreement of PJM Interconnection, L.L.C. ("PJM Operating Agreement"), Schedule 1.

Honorable Kimberly D. Bose  
February 12, 2015  
Page 5

generator and PJM. These provisions establish reasonable and necessary standards and qualifications, such as revenue quality metering, both to enable the generator to participate as a Market Seller<sup>16</sup> in PJM's market and to allow PJM's system operations the necessary visibility to the generator for reliability purposes. However, the WMPA is not an ISA and is not intended as a substitute for an interconnection agreement between the owners of the interconnecting physical facilities.

More specifically, the WMPA differs from the ISA in several key respects. First, the WMPA does not contain any reference to attachment facilities necessary for the interconnection. The WMPA also does not reference network upgrades for the interconnection to the distribution facility. In limited circumstances, the Feasibility Study and/or the System Impact Study may conclude that there is a significant impact to other jurisdictional interconnections that are located on the nearest transmission system, or a possible impact to facilities that are located on a nearby Commission-jurisdictional distribution facility. If this were the case, the interconnecting generator could be required to fund network upgrades on the corresponding jurisdictional systems only. In the event additional upgrades were needed, the WMPA contains proposed language concerning "Responsibility for Network or Local Upgrades" in Article 3 of the WMPA. At the discretion of the Parties, they may simply mark this section as "not applicable" or delete the section from the WMPA in its entirety when this contract language is inapplicable (as it will be in the majority of cases).

Generally, the WMPA does not contain security requirements (with the limited exception as explained above), or construction requirements. The WMPA also makes no reference to reactive power requirements, and construction of transmission owner interconnection facilities. These are the key components of the ISA that are not included in the WMPA because these ISA components are not relevant to the wholesale transactions.

## **V. Waiver and Effective Date**

PJM requests that the Commission grant any and all waivers of the Commission's rules and regulations that are necessary for acceptance of this filing and the enclosed WMPA. Additionally, PJM requests a waiver of the Commission's 60-day prior notice requirement to allow an effective date of January 14, 2015, for the WMPA, as set forth in § 1.1 thereof. Waiver is appropriate because the WMPA is being filed within thirty (30) days of its requested effective date. *See Prior Notice and Filing Requirements Under Part II of the Federal Power Act*, 64 FERC ¶ 61,139 at 61,983-84 (1993).

## **VI. Documents Enclosed**

PJM encloses the following:

1. This Transmittal Letter;
2. WMPA – Service Agreement No. 4093;

---

<sup>16</sup> *See Market Seller* defined in the PJM Operating Agreement at § 1.23.

Honorable Kimberly D. Bose  
February 12, 2015  
Page 6

3. Attachment A: Copy of sheet(s) containing original signatures.

## VII. Service

Copies of this filing have been served upon the parties, URC and Penelec, at the addresses listed below, as well as on the affected state utility commission(s) within the PJM region.

## VIII. Correspondence and Communications

All notices, communications or correspondence addressed to PJM regarding this matter should be directed to, and PJM requests that the Secretary include on the Commission's official service list, the following:

Robert V. Eckenrod  
Senior Counsel  
PJM Interconnection, L.L.C.  
2750 Monroe Blvd.  
Audubon, Pennsylvania 19403  
(610) 666-3184  
*robert.eckenrod@pjm.com*

Craig Glazer  
Vice President – Federal Government Policy  
PJM Interconnection, L.L.C.  
1200 G Street, N.W. Suite 600  
Washington, D.C. 20005  
(202) 393-7756  
*craig.glazer@pjm.com*

## V. Service

PJM has served a copy of this filing on the Wholesale Market Participant, Transmission Owner and the relevant state regulatory commission within the PJM region.

Respectfully submitted,



Craig Glazer  
Vice President – Federal Government Policy  
PJM Interconnection, L.L.C.

Robert V. Eckenrod  
Senior Counsel  
PJM Interconnection, L.L.C.

Honorable Kimberly D. Bose  
February 12, 2015  
Page 7

cc: United Refining Company  
15 Bradley St  
Warren, PA 16365  
Attn: David Dorn

Pennsylvania Electric Company  
76 South Main Street  
A-GO-10  
Akron, OH 44308  
Attn: Mike Thorn, Agreements Support Manager

FirstEnergy Service Company  
Legal Department  
76 South Main Street  
A-GO-15  
Akron, OH 44308  
Attn: Attorney for Agreements Support

Pennsylvania Public Utility Commission  
P.O. Box 3265  
Harrisburg, PA 17105-3265  
ATTN: General Counsel

Service Agreement No. 4093

(PJM Queue #Y2-055)

**WHOLESALE MARKET PARTICIPATION AGREEMENT**  
**Among**  
**PJM INTERCONNECTION, L.L.C.**  
**And**  
**UNITED REFINING COMPANY**  
**And**  
**PENNSYLVANIA ELECTRIC COMPANY**



Service Agreement No. 4093

**WHOLESALE MARKET PARTICIPATION AGREEMENT**

**By and Among  
PJM Interconnection, L.L.C.  
And  
United Refining Company  
And  
Pennsylvania Electric Company  
(PJM Queue Position #Y2-055)**

This Wholesale Market Participation Agreement (“WMPA”) including the Specifications, and Schedules attached hereto and incorporated herein, is entered into in order to effectuate sales of energy and/or capacity into PJM’s wholesale markets, by and between PJM Interconnection, L.L.C., the Regional Transmission Organization for the PJM Region (“Transmission Provider”), United Refining Company (“Wholesale Market Participant” or “URC”) and Pennsylvania Electric Company (“Transmission Owner” or “Penelec”) (referred to individually as “Party” or collectively as “the Parties”).

**WITNESSETH**

WHEREAS, Wholesale Market Participant is developing generation that it intends to use to engage in Wholesale Transactions in PJM’s markets and desires to maintain its proposed generation in the queue that PJM studies for potential reliability impacts to the Transmission System;

WHEREAS, Wholesale Market Participant is seeking to interconnect at a local distribution or sub-transmission facility, which at this time is not subject to FERC jurisdiction; and

WHEREAS, Wholesale Market Participant and Transmission Owner or its affiliate must enter into a separate two-party interconnection agreement (“Interconnection Agreement”) in order to address issues of physical interconnection and local charges that may be presented by the interconnection of Wholesale Market Participant’s generation to the distribution facility.

NOW, THEREFORE, in consideration of the mutual covenants herein contained, together with other good and valuable consideration, the receipt and sufficiency is hereby mutually acknowledged by Transmission Provider, Transmission Owner and Wholesale Market Participant and the parties agree to assume all of the rights and obligations consistent with the rights and obligations relating to Network Upgrades, Local Upgrades and metering requirements set forth in Part VI of the Tariff, as of the effective date of this WMPA, required for Wholesale Market Participant to make Wholesale Transactions in PJM’s markets. The Parties mutually covenant and agree as follows:

## Article 1 – DEFINITIONS and OTHER DOCUMENTS

- 1.0 Defined Terms.** All capitalized terms herein shall have the meanings as set forth in the definitions of such terms as stated in Part I, Article 1 or Part VI of the PJM Open Access Transmission Tariff (“Tariff”), except Wholesale Market Participant which shall be defined in this WMPA as a participant in a Wholesale Transaction.
- 1.1 Effective Date.** This WMPA shall become effective on the date it is executed by all Parties, or, if this WMPA is filed with FERC unexecuted, upon the date specified by FERC. This WMPA shall terminate on such date as mutually agreed upon by the parties, unless earlier terminated consistent with Section 1 in Attachment O, Appendix 2, Part VI of the Tariff.
- 1.2 Assumption of Tariff Obligations.** Wholesale Market Participant agrees to abide by all rules and procedures pertaining to generation and transmission in the PJM Region, including but not limited to the rules and procedures concerning the dispatch of generation or scheduling transmission set forth in the Tariff, the Operating Agreement and the PJM Manuals.
- 1.3 Incorporation Of Other Documents.** All portions of the Tariff and the Operating Agreement pertinent to the subject matter of this WMPA and not otherwise made a part hereof are hereby incorporated herein and made a part hereof.

## Article 2 - NOTICES and MISCELLANEOUS

- 2.0 Notices.** Any notice, demand or request required or permitted to be given by any Party to another and any instrument required or permitted to be tendered or delivered by any Party in writing to another may be so given, tendered or delivered by recognized national courier or by depositing the same with the United States Postal Service, with postage prepaid for delivery by certified or registered mail addressed to the Party, or by personal delivery to the Party, at the address specified below. Such notices, if agreed to by the Parties, may be made via electronic means, with e-mail confirmation of delivery.

Transmission Provider:

PJM Interconnection, L.L.C.  
2750 Monroe Blvd.  
Audubon, PA 19403-2497

Wholesale Market Participant:  
United Refining Company  
15 Bradley St  
Warren, PA 16365  
Attn: David Dorn

Transmission Owner:

Pennsylvania Electric Company  
76 South Main Street  
A-GO-10  
Akron, OH 44308  
Attn: Mike Thorn, Agreements Support Manager

With copies to:  
FirstEnergy Service Company  
Legal Department  
76 South Main Street  
A-GO-15  
Akron, OH 44308  
Attn: Attorney for Agreements Support

Either Party may change its address or designated representative for notice by notice to the other Parties in the manner provided for above.

- 2.1 Construction With Other Parts Of The Tariff.** This WMPA shall not be construed as an application for service under Part II or Part III of the Tariff.
- 2.2 Warranty for Facilities Study.** In analyzing and preparing the Generation Interconnection Facilities Study, and in designing and constructing the Local Upgrades and/or Network Upgrades described in Part II of the Tariff and in the Specifications attached to this WMPA, Transmission Provider, the Transmission Owner(s), and any other subcontractors employed by Transmission Provider have had to, and shall have to, rely on information provided by Wholesale Market Participant and possibly by third parties and may not have control over the accuracy of such information. Accordingly, NEITHER TRANSMISSION PROVIDER, THE TRANSMISSION OWNER(s), NOR ANY OTHER SUBCONTRACTORS EMPLOYED BY TRANSMISSION PROVIDER OR TRANSMISSION OWNER MAKES ANY WARRANTIES, EXPRESS OR IMPLIED, WHETHER ARISING BY OPERATION OF LAW, COURSE OF PERFORMANCE OR DEALING, CUSTOM, USAGE IN THE TRADE OR PROFESSION, OR OTHERWISE, INCLUDING WITHOUT LIMITATION IMPLIED WARRANTIES OF MERCHANTABILITY AND FITNESS FOR A PARTICULAR PURPOSE, WITH REGARD TO THE ACCURACY, CONTENT, OR CONCLUSIONS OF THE FACILITIES STUDY OR THE SYSTEM IMPACT STUDY IF A FACILITIES STUDY WAS NOT REQUIRED OR OF THE LOCAL UPGRADES AND/OR THE NETWORK UPGRADES, PROVIDED, HOWEVER, that Transmission Provider warrants that the Transmission Owner Facilities described in the Specifications will be designed and constructed (to the extent that Transmission Owner is responsible for design and construction thereof) and operated in accordance with Good Utility Practice, as such term is defined in the Operating Agreement. Wholesale Market Participant acknowledges that it has not relied on any representations or warranties not specifically

set forth herein and that no such representations or warranties have formed the basis of its bargain hereunder.

- 2.3 Waiver.** No waiver by any party of one or more defaults by the other in performance of any of the provisions of this WMPA shall operate or be construed as a waiver of any other or further default or defaults, whether of a like or different character.
- 2.4 Amendment.** This WMPA or any part thereof, may not be amended, modified, or waived other than by a written document signed by all parties hereto.
- 2.5 Addendum of Wholesale Market Participant's Agreement to Conform with IRS Safe Harbor Provisions for Non-Taxable Status.** To the extent required, in accordance with Section 24.1 in Attachment O, Appendix 2 in Part VI of the Tariff, Schedule E to this WMPA shall set forth the Wholesale Market Participant's agreement to conform with the IRS safe harbor provisions for non-taxable status.
- 2.6 Assignment**

**2.6.1 Assignment with Prior Consent:**

If the Interconnection Agreement between the Wholesale Market Participant and the Transmission Owner, as referenced in section 3.1.4 herein, provides that such Interconnection Agreement may be assigned, and such Interconnection Agreement was assigned, then, except as provided in Section 2.6.2 of this WMPA, no Party shall assign its rights or delegate its duties under this WMPA without the prior written consent of the other Parties, which consent shall not be unreasonably withheld, conditioned, or delayed; and any such assignment or delegation made without such prior written consent shall be null and void. A Party may make an assignment in connection with the sale, merger, or transfer of all of its properties, including the Participant Facility, which it owns, so long as the assignee in such a sale, merger, or transfer assumes in writing all rights, duties and obligations arising under this WMPA. In addition, the Transmission Owner shall be entitled, subject to applicable laws and regulations, to assign the WMPA to an Affiliate or successor that owns and operates all or a substantial portion of the Transmission Owner's transmission facilities.

**2.6.2 Assignment without Prior Consent**

If the Interconnection Agreement between the Wholesale Market Participant and the Transmission Owner, as referenced in section 3.1.4 herein, provides that such Interconnection Agreement may be assigned, and such Interconnection Agreement was assigned, then the Wholesale Market Participant may assign its rights or delegate its duties under this WMPA without the Transmission Owner's or Transmission Provider's prior consent to any Affiliate or person that purchases or otherwise acquires, directly or indirectly, all of the Participant Facility, provided that prior to the effective date of any such assignment: (1) the assignee shall demonstrate that, as of the effective date of the assignment, the assignee has the technical and operational competence to comply with the requirements of this WMPA; and (2) in writing to the Transmission Owner and

Transmission Provider, assignee assumes all rights, duties, and obligations of Wholesale Market Participant arising under this WMPA. However, any assignment described herein shall not relieve or discharge the Wholesale Market Participant from any of its obligations hereunder absent the written consent of the Transmission Provider, such consent not to be unreasonably withheld, conditioned or delayed.

**2.6.3 Successors and Assigns:**

This WMPA and all of its provisions are binding upon, and inure to the benefit of, the Parties and their respective successors and permitted assigns.

## ARTICLE 3 – Responsibility for Network or Local Upgrades

- 3.0 Security for Network or Local Upgrades.** Consistent with Section 212.4 in Part VI of the Tariff, Wholesale Market Participant, on or before the effective date of this WMPA, shall provide the Transmission Provider (for the benefit of the Transmission Owner) with a letter of credit from an agreed provider or other form of security reasonably acceptable to the Transmission Provider and that names the Transmission Provider as beneficiary (“Security”) in the amount of \$0. This amount represents the sum of the estimated Costs, determined consistent with Section 217 in Part VI of the Tariff, of (i) the Local Upgrades and/or Network Upgrades described in Section 3.4 of this WMPA less any Costs already paid by the Wholesale Market Participant. Should Wholesale Market Participant fail to provide Security in the amount or form required in the first sentence of this Section, this WMPA shall be terminated. Wholesale Market Participant acknowledges that its ultimate cost responsibility consistent with Section 217 in Part VI of the Tariff will be based upon the actual Costs of the facilities described in the Specifications to this WMPA, whether greater or lesser than the amount of the Security provided under this Section.
- 3.1 Project Specific Milestones.** During the term of this WMPA, Wholesale Market Participant shall ensure that it meets each of the following milestones:
- 3.1.1 Substantial Site work completed.** On or before January 1, 2017, Wholesale Market Participant must demonstrate completion of at least 20% of project site construction.
- 3.1.2 Commercial Operation.** (i) On or before January 1, 2018, Wholesale Market Participant must demonstrate commercial operation of all generating units; (ii) On or before September 1, 2018, Wholesale Market Participant must demonstrate commercial sale or use of energy and, if applicable obtain capacity qualification consistent with the requirements of the Reliability Assurance Agreement Among Load Serving Entities in the PJM Region.
- 3.1.3 Documentation.** Within one (1) month following commercial operation of generating unit(s), Wholesale Market Participant must provide certified documentation demonstrating that “as-built” Participant Facility are consistent with applicable PJM studies and agreements. Wholesale Market Participant must also provide PJM with “as-built” electrical modeling data or confirm that previously submitted data remains valid.
- 3.1.4 Interconnection Agreement.** On or before January 1, 2016, Wholesale Market Participant must enter into an Interconnection Agreement with the Transmission Owner in order to effectuate the WMPA.

Wholesale Market Participant shall demonstrate the occurrence of each of the foregoing milestones to Transmission Provider’s reasonable satisfaction. Transmission Provider may reasonably extend any such milestone dates, in the event of delays that Wholesale

Market Participant (i) did not cause and (ii) could not have remedied through the exercise of due diligence.

If (i) the Wholesale Market Participant suspends work pursuant to a suspension provision contained in an interconnection and/or construction agreement with the Transmission Owner or (ii) the Transmission Owner extends the date by which Wholesale Market Participant must enter into an interconnection agreement relative to this WMPA, and (iii) the Wholesale Market Participant has not made a wholesale sale under this WMPA, the Wholesale Market Participant may suspend this WMPA by notifying the Transmission Provider and the Transmission Owner in writing that it wishes to suspend this WMPA, with the condition that, notwithstanding such suspension, the Transmission System shall be left in a safe and reliable condition in accordance with Good Utility Practice and Transmission Provider's safety and reliability criteria. Wholesale Market Participant's notice of suspension shall include an estimated duration of the suspension period and other information related to the suspension. Pursuant to this section 3.1, Wholesale Market Participant may request one or more suspensions of work under this WMPA for a cumulative period of up to a maximum of three years. If, however, the suspension will result in a Material Modification as defined in Part I, Section 1.18A.02 of the Tariff, then such suspension period shall be no greater than one (1) year. If the Wholesale Market Participant suspends this WMPA pursuant to this Section 3.1 and has not provided written notice that it will exit such suspension on or before the expiration of the suspension period described herein, this WMPA shall be deemed terminated as of the end of such suspension period. The suspension time shall begin on the date the suspension is requested or on the date of the Wholesale Market Participant's written notice of suspension to Transmission Provider, if no effective date was specified. All milestone dates stated in this Section 3.1 shall be deemed to be extended coextensively with any suspension period permitted pursuant to this provision.

IN WITNESS WHEREOF, Transmission Provider, Wholesale Market Participant and Transmission Owner have caused this WMPA to be executed by their respective authorized officials.

(PJM Queue #Y2-055)

Transmission Provider: PJM Interconnection, L.L.C.

By: <u>/s/ David M. Egan</u>	<u>Manager -</u> <u>Interconnection Planning</u>	<u>1/14/15</u>
Name	Title	Date

Printed name of signer: David M. Egan

Wholesale Market Participant: **United Refining Company**

By: <u>/s/ Richard G. Curren, Jr.</u>	<u>Vice President – Purchasing</u>	<u>12/19/14</u>
Name	Title	Date

Printed name of signer: Richard G. Curren, Jr.

Transmission Owner: **Pennsylvania Electric Company**

By: <u>/s/ Scott R. Wyman</u>	<u>President</u>	<u>1/6/15</u>
Name	Title	Date

Printed name of signer: Scott R. Wyman



**SPECIFICATIONS FOR  
WHOLESALE MARKET PARTICIPATION AGREEMENT  
By and Among  
PJM INTERCONNECTION, L.L.C.  
And  
UNITED REFINING COMPANY  
And  
PENNSYLVANIA ELECTRIC COMPANY  
(PJM Queue Position # Y2-055)**

**1.0 Description of generating unit(s)** (the “Participant Facility”) to be used for the provision of wholesale sales into the PJM markets:

a. Name of Participant Facility:

United Refining Company Oil Refinery

b. Location of Participant Facility:

Dobson Avenue, Warren, PA

c. Size in megawatts of Participant Facility:

Maximum Facility Output of 29 MW

d. Description of the equipment configuration:

Combustion Turbine Generator set, 13.8kV/34.5 kV GSU and 34.5 kV line to FirstEnergy Elm Street substation, serving refinery load with net output to FE distribution system of 29 MW.

## **2.0 Rights for Generation Wholesale Market Participant**

### **2.1 Capacity Interconnection Rights:**

Consistent with the applicable terms of the Tariff, the Wholesale Market Participant shall have Capacity Interconnection Rights at the point(s) of interconnection specified in Schedule A of this Wholesale Market Participant Agreement in the amount of 29 MW; provided however, nothing in this WMPA provides any rights with regard to the use of distribution facilities.

Pursuant to and subject to the applicable terms of the Tariff, the Wholesale Market Participant shall have Capacity Interconnection Rights at the Point(s) of Interconnection specified in this Wholesale Market Participation Agreement in the amount of 29 MW commencing June 1, 2016. During the time period from the effective date of this WMPA until May 31, 2016 (the “interim time period”), the Wholesale Market Participant may be awarded interim Capacity Interconnection Rights in an amount not to exceed 29 MW. The availability and amount of such interim Capacity Interconnection Rights shall be dependent upon completion and results of an interim deliverability study. Any interim Capacity Interconnection Rights awarded during the interim time period shall terminate on May 31, 2016.

To the extent that any portion of the Participant Facility described in Section 1.0 is not a Capacity Resource with Capacity Interconnection Rights, such portion of the Participant Facility shall be an Energy Resource. Pursuant to this WMPA, the Wholesale Market Participant may sell energy into PJM’s markets in an amount equal to the Participant Facility’s Maximum Facility Output indicated in Section 1.0c of the Specifications for this WMPA. PJM reserves the right to limit injections in the event reliability would be affected by output greater than such quantity.

**3.0 Ownership and Location of Metering Equipment.** The metering equipment to be constructed, the capability of the metering equipment to be constructed, and the ownership thereof, as required for the Wholesale Transactions shall be identified on the attached Schedule B to this WMPA, and provided consistent with the PJM manuals.

**SCHEDULES:**

- **SCHEDULE A - SINGLE-LINE DIAGRAM (Showing point of interconnection)**
- **SCHEDULE B - LIST OF METERING EQUIPMENT**
- **SCHEDULE C - LIST OF LOCAL/NETWORK UPGRADES**
- **SCHEDULE D - APPLICABLE TECHNICAL REQUIREMENTS AND STANDARDS**
- **SCHEDULE E - WHOLESALE MARKET PARTICIPANT AGREEMENT TO CONFORM WITH IRS SAFE HARBOR PROVISIONS FOR NON-TAXABLE STATUS**
- **SCHEDULE F –SCHEDULE OF NON-STANDARD TERMS & CONDITIONS**

### SCHEDULE A SINGLE-LINE DIAGRAM

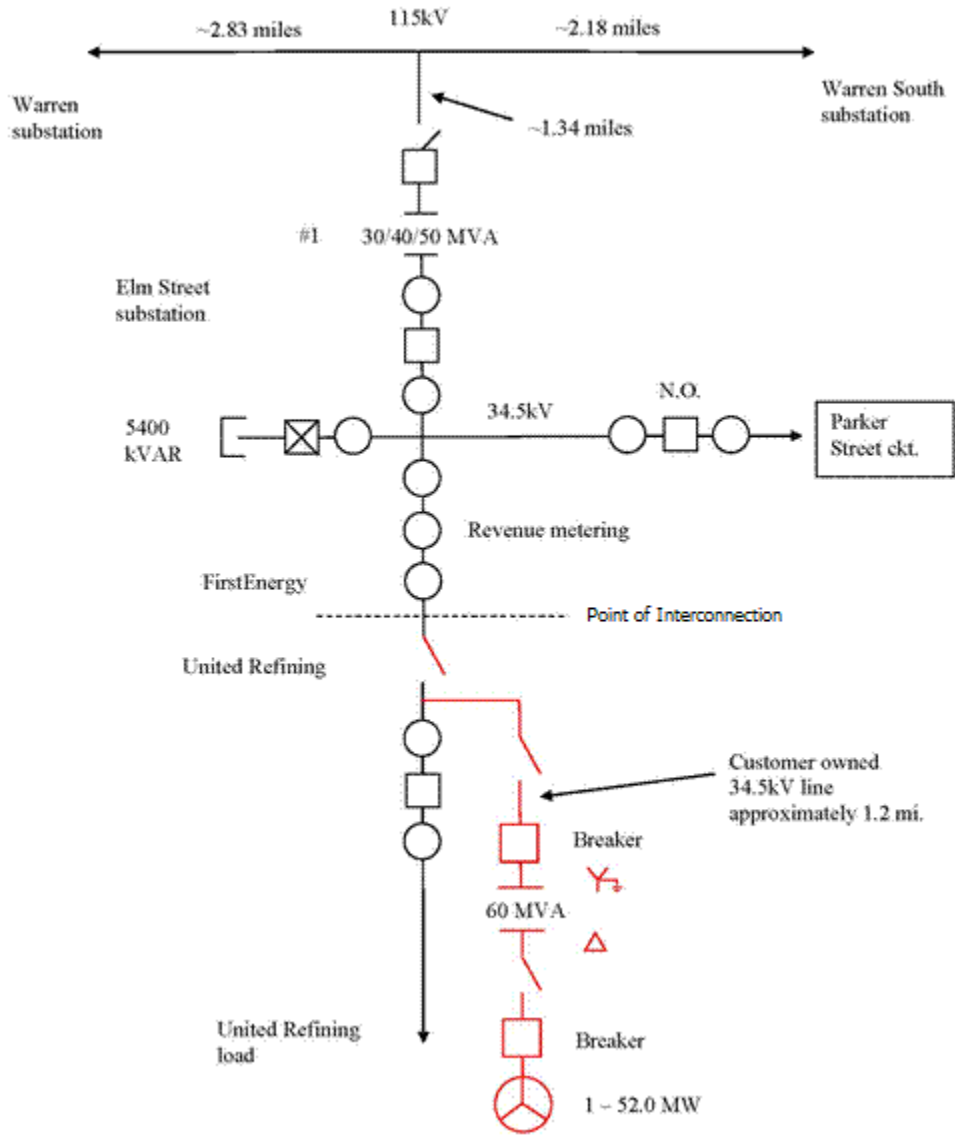

**SCHEDULE B**  
**LIST OF METERING EQUIPMENT**

Not Required.

**SCHEDULE C**

**LIST OF LOCAL/NETWORK UPGRADES**

Not Required.

**SCHEDULE D**

**APPLICABLE TECHNICAL REQUIREMENTS AND STANDARDS**

Not Required.

**SCHEDULE E**  
**WHOLESALE MARKET PARTICIPANT'S AGREEMENT TO CONFORM WITH IRS**  
**SAFE HARBOR PROVISIONS FOR NON-TAXABLE STATUS**

As provided in Section 24.1 in Attachment O, Appendix 2 in Part VI of the Tariff and subject to the requirements thereof, Wholesale Market Participant represents that it meets all qualifications and requirements as set forth in Section 118(a) and 118(b) of the Internal Revenue Code of 1986, as amended and interpreted by Notice 88-129, 1988-2 C.B. 541, and as amplified and modified in Notices 90-60, 1990-2 C.B. 345, and 2001-82, 2001-2 C.B. 619 (the "IRS Notices"). Wholesale Market Participant agrees to conform with all requirements of the safe harbor provisions specified in the IRS Notices, as they may be amended, as required to confer non-taxable status on some or all of the transfer of property, including money, by Wholesale Market Participant to Transmission Owner with respect to the payment of the Costs of construction and installation of the Transmission Owner Interconnection Facilities specified in this WMPA.

Nothing in Wholesale Market Participant's agreement pursuant to this Schedule E shall change the indemnification obligations under Section 24.2 in Attachment O, Appendix 2 in Part VI of the Tariff.



**SCHEDULE F**  
**SCHEDULE OF NON-STANDARD TERMS & CONDITIONS**

Not Required.

# Attachment A

Copy of Original Signature Page(s)  
Service Agreement No. 4093

IN WITNESS WHEREOF, Transmission Provider, Wholesale Market Participant and Transmission Owner have caused this WMPA to be executed by their respective authorized officials.

(PJM Queue #Y2-055)

Transmission Provider: PJM Interconnection, L.L.C.

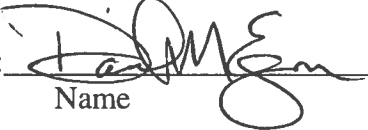
By:  David M. Egan 1/14/15  
Name Title Date  
Manager, Interconnection Planning

Printed name of signer: \_\_\_\_\_

Wholesale Market Participant: **United Refining Company**

By: \_\_\_\_\_  
Name Title Date

Printed name of signer: \_\_\_\_\_

Transmission Owner: **Pennsylvania Electric Company**

By: \_\_\_\_\_  
Name Title Date

Printed name of signer: \_\_\_\_\_

IN WITNESS WHEREOF, Transmission Provider, Wholesale Market Participant and Transmission Owner have caused this WMPA to be executed by their respective authorized officials.

(PJM Queue #Y2-055)

Transmission Provider: PJM Interconnection, L.L.C.

By: \_\_\_\_\_  
Name Title Date

Printed name of signer: \_\_\_\_\_

Wholesale Market Participant: **United Refining Company**

By: Richard G. Curren, Jr. VICE PRESIDENT, - PURCHASING 12/19/14  
Name Title Date

Printed name of signer: Richard G. Curren, Jr.

Transmission Owner: **Pennsylvania Electric Company**

By: \_\_\_\_\_  
Name Title Date

Printed name of signer: \_\_\_\_\_

IN WITNESS WHEREOF, Transmission Provider, Wholesale Market Participant and Transmission Owner have caused this WMPA to be executed by their respective authorized officials.

(PJM Queue #Y2-055)

Transmission Provider: PJM Interconnection, L.L.C.

By: \_\_\_\_\_  
Name Title Date

Printed name of signer: \_\_\_\_\_

Wholesale Market Participant: **United Refining Company**

By: \_\_\_\_\_  
Name Title Date

Printed name of signer: \_\_\_\_\_

Transmission Owner: **Pennsylvania Electric Company**

By: Scott Wyman \_\_\_\_\_  
Name Title Date  
*President* *11/15*

Printed name of signer: SCOTT R. WYMAN

FERC rendition of the electronically filed tariff records in Docket No. ER15-01033-000

Filing Data:

CID: C000030

Filing Title: Original Service Agreement No. 4093; Queue Y2-055 (WMPA)

Company Filing Identifier: 1636

Type of Filing Code: 10

Associated Filing Identifier:

Tariff Title: PJM Service Agreements Tariff

Tariff ID: 40

Payment Confirmation:

Suspension Motion:

Tariff Record Data:

Record Content Description, Tariff Record Title, Record Version Number, Option Code:

PJM SA No. 4093, PJM SA No. 4093 among PJM, United Refining and Penelec, 0.0.0, A

Record Narrative Name: PJM SA No. 4093 - an executed Wholesale Market Participation Agreement By and Among

PJM Interconnection, L.L.C., United Refining Company and Pennsylvania Electric Company

Tariff Record ID: 1083

Tariff Record Collation Value: 546601760 Tariff Record Parent Identifier: 0

Proposed Date: 2015-01-14

Priority Order: 500

Record Change Type: NEW

Record Content Type: 1

Associated Filing Identifier:

Service Agreement No. 4093

(PJM Queue #Y2-055)

**WHOLESALE MARKET PARTICIPATION AGREEMENT**

**Among**

**PJM INTERCONNECTION, L.L.C.**

**And**

**UNITED REFINING COMPANY**

**And**

**PENNSYLVANIA ELECTRIC COMPANY**

Service Agreement No. 4093

**WHOLESALE MARKET PARTICIPATION AGREEMENT**

**By and Among  
PJM Interconnection, L.L.C.  
And  
United Refining Company  
And  
Pennsylvania Electric Company  
(PJM Queue Position #Y2-055)**

This Wholesale Market Participation Agreement (“WMPA”) including the Specifications, and Schedules attached hereto and incorporated herein, is entered into in order to effectuate sales of energy and/or capacity into PJM’s wholesale markets, by and between PJM Interconnection, L.L.C., the Regional Transmission Organization for the PJM Region (“Transmission Provider”), United Refining Company (“Wholesale Market Participant” or “URC”) and Pennsylvania Electric Company (“Transmission Owner” or “Penelec”) (referred to individually as “Party” or collectively as “the Parties”).

**WITNESSETH**

WHEREAS, Wholesale Market Participant is developing generation that it intends to use to engage in Wholesale Transactions in PJM’s markets and desires to maintain its proposed generation in the queue that PJM studies for potential reliability impacts to the Transmission System;

WHEREAS, Wholesale Market Participant is seeking to interconnect at a local distribution or sub-transmission facility, which at this time is not subject to FERC jurisdiction; and

WHEREAS, Wholesale Market Participant and Transmission Owner or its affiliate must enter into a separate two-party interconnection agreement (“Interconnection Agreement”) in order to address issues of physical interconnection and local charges that may be presented by the interconnection of Wholesale Market Participant’s generation to the distribution facility.

NOW, THEREFORE, in consideration of the mutual covenants herein contained, together with other good and valuable consideration, the receipt and sufficiency is hereby mutually acknowledged by Transmission Provider, Transmission Owner and Wholesale Market Participant and the parties agree to assume all of the rights and obligations consistent with the rights and obligations relating to Network Upgrades, Local Upgrades and metering requirements set forth in Part VI of the Tariff, as of the effective date of this

WMPA, required for Wholesale Market Participant to make Wholesale Transactions in PJM's markets. The Parties mutually covenant and agree as follows:

### **Article 1 – DEFINITIONS and OTHER DOCUMENTS**

- 1.0 Defined Terms.** All capitalized terms herein shall have the meanings as set forth in the definitions of such terms as stated in Part I, Article 1 or Part VI of the PJM Open Access Transmission Tariff (“Tariff”), except Wholesale Market Participant which shall be defined in this WMPA as a participant in a Wholesale Transaction.
- 1.1 Effective Date.** This WMPA shall become effective on the date it is executed by all Parties, or, if this WMPA is filed with FERC unexecuted, upon the date specified by FERC. This WMPA shall terminate on such date as mutually agreed upon by the parties, unless earlier terminated consistent with Section 1 in Attachment O, Appendix 2, Part VI of the Tariff.
- 1.2 Assumption of Tariff Obligations.** Wholesale Market Participant agrees to abide by all rules and procedures pertaining to generation and transmission in the PJM Region, including but not limited to the rules and procedures concerning the dispatch of generation or scheduling transmission set forth in the Tariff, the Operating Agreement and the PJM Manuals.
- 1.3 Incorporation Of Other Documents.** All portions of the Tariff and the Operating Agreement pertinent to the subject matter of this WMPA and not otherwise made a part hereof are hereby incorporated herein and made a part hereof.

### **Article 2 - NOTICES and MISCELLANEOUS**

- 2.0 Notices.** Any notice, demand or request required or permitted to be given by any Party to another and any instrument required or permitted to be tendered or delivered by any Party in writing to another may be so given, tendered or delivered by recognized national courier or by depositing the same with the United States Postal Service, with postage prepaid for delivery by certified or registered mail addressed to the Party, or by personal delivery to the Party, at the address specified below. Such notices, if agreed to by the Parties, may be made via electronic means, with e-mail confirmation of delivery.

Transmission Provider:

PJM Interconnection, L.L.C.  
2750 Monroe Blvd.  
Audubon, PA 19403-2497

Wholesale Market Participant:



United Refining Company  
15 Bradley St  
Warren, PA 16365  
Attn: David Dorn

Transmission Owner:

Pennsylvania Electric Company  
76 South Main Street  
A-GO-10  
Akron, OH 44308  
Attn: Mike Thorn, Agreements Support Manager

With copies to:  
FirstEnergy Service Company  
Legal Department  
76 South Main Street  
A-GO-15  
Akron, OH 44308  
Attn: Attorney for Agreements Support

Either Party may change its address or designated representative for notice by notice to the other Parties in the manner provided for above.

- 2.1 Construction With Other Parts Of The Tariff.** This WMPA shall not be construed as an application for service under Part II or Part III of the Tariff.
- 2.2 Warranty for Facilities Study.** In analyzing and preparing the Generation Interconnection Facilities Study, and in designing and constructing the Local Upgrades and/or Network Upgrades described in Part II of the Tariff and in the Specifications attached to this WMPA, Transmission Provider, the Transmission Owner(s), and any other subcontractors employed by Transmission Provider have had to, and shall have to, rely on information provided by Wholesale Market Participant and possibly by third parties and may not have control over the accuracy of such information. Accordingly, NEITHER TRANSMISSION PROVIDER, THE TRANSMISSION OWNER(s), NOR ANY OTHER SUBCONTRACTORS EMPLOYED BY TRANSMISSION PROVIDER OR TRANSMISSION OWNER MAKES ANY WARRANTIES, EXPRESS OR IMPLIED, WHETHER ARISING BY OPERATION OF LAW, COURSE OF PERFORMANCE OR DEALING, CUSTOM, USAGE IN THE TRADE OR PROFESSION, OR OTHERWISE, INCLUDING WITHOUT LIMITATION IMPLIED WARRANTIES OF MERCHANTABILITY AND FITNESS FOR A PARTICULAR PURPOSE, WITH REGARD TO THE ACCURACY, CONTENT, OR CONCLUSIONS OF THE FACILITIES STUDY OR THE SYSTEM IMPACT STUDY IF A FACILITIES STUDY WAS NOT REQUIRED OR OF THE LOCAL UPGRADES AND/OR THE NETWORK UPGRADES, PROVIDED, HOWEVER, that Transmission Provider warrants that the Transmission Owner Facilities described in the Specifications will be designed and constructed (to the extent that Transmission Owner is responsible for design and construction thereof) and operated in accordance with Good Utility Practice, as such term is defined in the Operating Agreement. Wholesale Market Participant acknowledges that it has not relied on any representations or warranties not specifically

set forth herein and that no such representations or warranties have formed the basis of its bargain hereunder.

- 2.3 Waiver.** No waiver by any party of one or more defaults by the other in performance of any of the provisions of this WMPA shall operate or be construed as a waiver of any other or further default or defaults, whether of a like or different character.
- 2.4 Amendment.** This WMPA or any part thereof, may not be amended, modified, or waived other than by a written document signed by all parties hereto.
- 2.5 Addendum of Wholesale Market Participant's Agreement to Conform with IRS Safe Harbor Provisions for Non-Taxable Status.** To the extent required, in accordance with Section 24.1 in Attachment O, Appendix 2 in Part VI of the Tariff, Schedule E to this WMPA shall set forth the Wholesale Market Participant's agreement to conform with the IRS safe harbor provisions for non-taxable status.
- 2.6 Assignment**

**2.6.1 Assignment with Prior Consent:**

If the Interconnection Agreement between the Wholesale Market Participant and the Transmission Owner, as referenced in section 3.1.4 herein, provides that such Interconnection Agreement may be assigned, and such Interconnection Agreement was assigned, then, except as provided in Section 2.6.2 of this WMPA, no Party shall assign its rights or delegate its duties under this WMPA without the prior written consent of the other Parties, which consent shall not be unreasonably withheld, conditioned, or delayed; and any such assignment or delegation made without such prior written consent shall be null and void. A Party may make an assignment in connection with the sale, merger, or transfer of all of its properties, including the Participant Facility, which it owns, so long as the assignee in such a sale, merger, or transfer assumes in writing all rights, duties and obligations arising under this WMPA. In addition, the Transmission Owner shall be entitled, subject to applicable laws and regulations, to assign the WMPA to an Affiliate or successor that owns and operates all or a substantial portion of the Transmission Owner's transmission facilities.

**2.6.2 Assignment without Prior Consent**

If the Interconnection Agreement between the Wholesale Market Participant and the Transmission Owner, as referenced in section 3.1.4 herein, provides that such Interconnection Agreement may be assigned, and such Interconnection Agreement was assigned, then the Wholesale Market Participant may assign its rights or delegate its duties under this WMPA without the Transmission Owner's or Transmission Provider's prior consent to any Affiliate or person that purchases or otherwise acquires, directly or indirectly, all of the Participant Facility, provided that prior to the effective date of any such assignment: (1) the assignee shall demonstrate that, as of the effective date of the assignment, the assignee has the technical and operational competence to comply with

the requirements of this WMPA; and (2) in writing to the Transmission Owner and Transmission Provider, assignee assumes all rights, duties, and obligations of Wholesale Market Participant arising under this WMPA. However, any assignment described herein shall not relieve or discharge the Wholesale Market Participant from any of its obligations hereunder absent the written consent of the Transmission Provider, such consent not to be unreasonably withheld, conditioned or delayed.

### **2.6.3 Successors and Assigns:**

This WMPA and all of its provisions are binding upon, and inure to the benefit of, the Parties and their respective successors and permitted assigns.

## ARTICLE 3 – Responsibility for Network or Local Upgrades

- 3.0 Security for Network or Local Upgrades.** Consistent with Section 212.4 in Part VI of the Tariff, Wholesale Market Participant, on or before the effective date of this WMPA, shall provide the Transmission Provider (for the benefit of the Transmission Owner) with a letter of credit from an agreed provider or other form of security reasonably acceptable to the Transmission Provider and that names the Transmission Provider as beneficiary (“Security”) in the amount of \$0. This amount represents the sum of the estimated Costs, determined consistent with Section 217 in Part VI of the Tariff, of (i) the Local Upgrades and/or Network Upgrades described in Section 3.4 of this WMPA less any Costs already paid by the Wholesale Market Participant. Should Wholesale Market Participant fail to provide Security in the amount or form required in the first sentence of this Section, this WMPA shall be terminated. Wholesale Market Participant acknowledges that its ultimate cost responsibility consistent with Section 217 in Part VI of the Tariff will be based upon the actual Costs of the facilities described in the Specifications to this WMPA, whether greater or lesser than the amount of the Security provided under this Section.
- 3.1 Project Specific Milestones.** During the term of this WMPA, Wholesale Market Participant shall ensure that it meets each of the following milestones:
- 3.1.1 Substantial Site work completed.** On or before January 1, 2017, Wholesale Market Participant must demonstrate completion of at least 20% of project site construction.
- 3.1.2 Commercial Operation.** (i) On or before January 1, 2018, Wholesale Market Participant must demonstrate commercial operation of all generating units; (ii) On or before September 1, 2018, Wholesale Market Participant must demonstrate commercial sale or use of energy and, if applicable obtain capacity qualification consistent with the requirements of the Reliability Assurance Agreement Among Load Serving Entities in the PJM Region.
- 3.1.3 Documentation.** Within one (1) month following commercial operation of generating unit(s), Wholesale Market Participant must provide certified documentation demonstrating that “as-built” Participant Facility are consistent with applicable PJM studies and agreements. Wholesale Market Participant must also provide PJM with “as-built” electrical modeling data or confirm that previously submitted data remains valid.
- 3.1.4 Interconnection Agreement.** On or before January 1, 2016, Wholesale Market Participant must enter into an Interconnection Agreement with the Transmission Owner in order to effectuate the WMPA.

Wholesale Market Participant shall demonstrate the occurrence of each of the foregoing milestones to Transmission Provider’s reasonable satisfaction. Transmission Provider may reasonably extend any such milestone dates, in the event of delays that Wholesale

Market Participant (i) did not cause and (ii) could not have remedied through the exercise of due diligence.

If (i) the Wholesale Market Participant suspends work pursuant to a suspension provision contained in an interconnection and/or construction agreement with the Transmission Owner or (ii) the Transmission Owner extends the date by which Wholesale Market Participant must enter into an interconnection agreement relative to this WMPA, and (iii) the Wholesale Market Participant has not made a wholesale sale under this WMPA, the Wholesale Market Participant may suspend this WMPA by notifying the Transmission Provider and the Transmission Owner in writing that it wishes to suspend this WMPA, with the condition that, notwithstanding such suspension, the Transmission System shall be left in a safe and reliable condition in accordance with Good Utility Practice and Transmission Provider's safety and reliability criteria. Wholesale Market Participant's notice of suspension shall include an estimated duration of the suspension period and other information related to the suspension. Pursuant to this section 3.1, Wholesale Market Participant may request one or more suspensions of work under this WMPA for a cumulative period of up to a maximum of three years. If, however, the suspension will result in a Material Modification as defined in Part I, Section 1.18A.02 of the Tariff, then such suspension period shall be no greater than one (1) year. If the Wholesale Market Participant suspends this WMPA pursuant to this Section 3.1 and has not provided written notice that it will exit such suspension on or before the expiration of the suspension period described herein, this WMPA shall be deemed terminated as of the end of such suspension period. The suspension time shall begin on the date the suspension is requested or on the date of the Wholesale Market Participant's written notice of suspension to Transmission Provider, if no effective date was specified. All milestone dates stated in this Section 3.1 shall be deemed to be extended coextensively with any suspension period permitted pursuant to this provision.

IN WITNESS WHEREOF, Transmission Provider, Wholesale Market Participant and Transmission Owner have caused this WMPA to be executed by their respective authorized officials.

(PJM Queue #Y2-055)

Transmission Provider: PJM Interconnection, L.L.C.

By: <u>/s/ David M. Egan</u>	<u>Manager -</u> <u>Interconnection Planning</u>	<u>1/14/15</u>
Name	Title	Date

Printed name of signer: David M. Egan

Wholesale Market Participant: **United Refining Company**

By: <u>/s/ Richard G. Curren, Jr.</u>	<u>Vice President – Purchasing</u>	<u>12/19/14</u>
Name	Title	Date

Printed name of signer: Richard G. Curren, Jr.

Transmission Owner: **Pennsylvania Electric Company**

By: <u>/s/ Scott R. Wyman</u>	<u>President</u>	<u>1/6/15</u>
Name	Title	Date

Printed name of signer: Scott R. Wyman

**SPECIFICATIONS FOR  
WHOLESALE MARKET PARTICIPATION AGREEMENT  
By and Among  
PJM INTERCONNECTION, L.L.C.  
And  
UNITED REFINING COMPANY  
And  
PENNSYLVANIA ELECTRIC COMPANY  
(PJM Queue Position # Y2-055)**

**1.0 Description of generating unit(s)** (the “Participant Facility”) to be used for the provision of wholesale sales into the PJM markets:

a. Name of Participant Facility:

United Refining Company Oil Refinery

b. Location of Participant Facility:

Dobson Avenue, Warren, PA

c. Size in megawatts of Participant Facility:

Maximum Facility Output of 29 MW

d. Description of the equipment configuration:

Combustion Turbine Generator set, 13.8kV/34.5 kV GSU and 34.5 kV line to FirstEnergy Elm Street substation, serving refinery load with net output to FE distribution system of 29 MW.



## **2.0 Rights for Generation Wholesale Market Participant**

### **2.1 Capacity Interconnection Rights:**

Consistent with the applicable terms of the Tariff, the Wholesale Market Participant shall have Capacity Interconnection Rights at the point(s) of interconnection specified in Schedule A of this Wholesale Market Participant Agreement in the amount of 29 MW; provided however, nothing in this WMPA provides any rights with regard to the use of distribution facilities.

Pursuant to and subject to the applicable terms of the Tariff, the Wholesale Market Participant shall have Capacity Interconnection Rights at the Point(s) of Interconnection specified in this Wholesale Market Participation Agreement in the amount of 29 MW commencing June 1, 2016. During the time period from the effective date of this WMPA until May 31, 2016 (the “interim time period”), the Wholesale Market Participant may be awarded interim Capacity Interconnection Rights in an amount not to exceed 29 MW. The availability and amount of such interim Capacity Interconnection Rights shall be dependent upon completion and results of an interim deliverability study. Any interim Capacity Interconnection Rights awarded during the interim time period shall terminate on May 31, 2016.

To the extent that any portion of the Participant Facility described in Section 1.0 is not a Capacity Resource with Capacity Interconnection Rights, such portion of the Participant Facility shall be an Energy Resource. Pursuant to this WMPA, the Wholesale Market Participant may sell energy into PJM’s markets in an amount equal to the Participant Facility’s Maximum Facility Output indicated in Section 1.0c of the Specifications for this WMPA. PJM reserves the right to limit injections in the event reliability would be affected by output greater than such quantity.

**3.0 Ownership and Location of Metering Equipment.** The metering equipment to be constructed, the capability of the metering equipment to be constructed, and the ownership thereof, as required for the Wholesale Transactions shall be identified on the attached Schedule B to this WMPA, and provided consistent with the PJM manuals.

**SCHEDULES:**

- **SCHEDULE A - SINGLE-LINE DIAGRAM (Showing point of interconnection)**
- **SCHEDULE B - LIST OF METERING EQUIPMENT**
- **SCHEDULE C - LIST OF LOCAL/NETWORK UPGRADES**
- **SCHEDULE D - APPLICABLE TECHNICAL REQUIREMENTS AND STANDARDS**
- **SCHEDULE E - WHOLESALE MARKET PARTICIPANT AGREEMENT TO CONFORM WITH IRS SAFE HARBOR PROVISIONS FOR NON-TAXABLE STATUS**
- **SCHEDULE F –SCHEDULE OF NON-STANDARD TERMS & CONDITIONS**

## SCHEDULE A SINGLE-LINE DIAGRAM

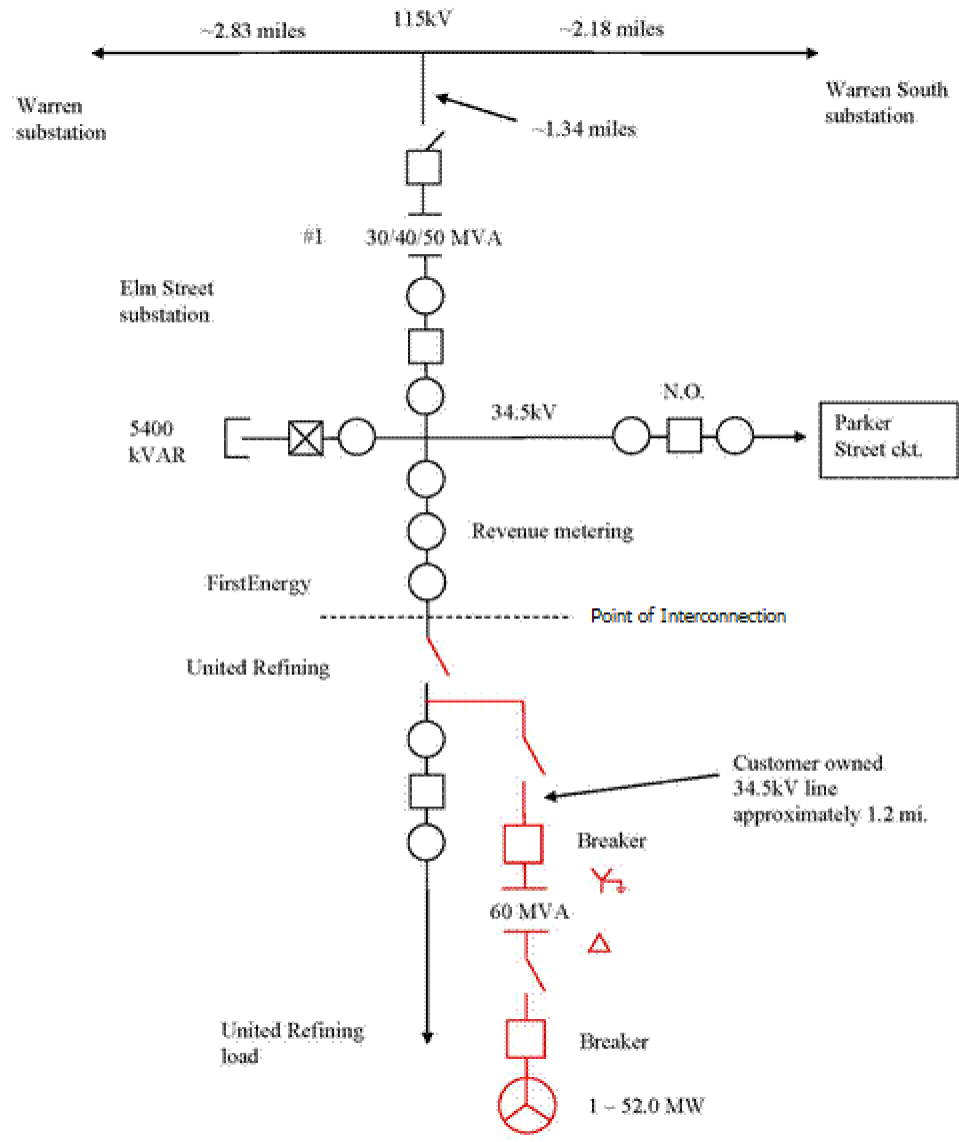

**SCHEDULE B**

**LIST OF METERING EQUIPMENT**

Not Required.**SCHEDULE C**

**LIST OF LOCAL/NETWORK UPGRADES**

Not Required.

## **SCHEDULE D**

### **APPLICABLE TECHNICAL REQUIREMENTS AND STANDARDS**

Not Required.

## **SCHEDULE E**

### **WHOLESALE MARKET PARTICIPANT'S AGREEMENT TO CONFORM WITH IRS SAFE HARBOR PROVISIONS FOR NON-TAXABLE STATUS**

As provided in Section 24.1 in Attachment O, Appendix 2 in Part VI of the Tariff and subject to the requirements thereof, Wholesale Market Participant represents that it meets all qualifications and requirements as set forth in Section 118(a) and 118(b) of the Internal Revenue Code of 1986, as amended and interpreted by Notice 88-129, 1988-2 C.B. 541, and as amplified and modified in Notices 90-60, 1990-2 C.B. 345, and 2001-82, 2001-2 C.B. 619 (the "IRS Notices"). Wholesale Market Participant agrees to conform with all requirements of the safe harbor provisions specified in the IRS Notices, as they may be amended, as required to confer non-taxable status on some or all of the transfer of property, including money, by Wholesale Market Participant to Transmission Owner with respect to the payment of the Costs of construction and installation of the Transmission Owner Interconnection Facilities specified in this WMPA.

Nothing in Wholesale Market Participant's agreement pursuant to this Schedule E shall change the indemnification obligations under Section 24.2 in Attachment O, Appendix 2 in Part VI of the Tariff.

**SCHEDULE F**  
**SCHEDULE OF NON-STANDARD TERMS & CONDITIONS**

Not Required.

Document Content(s)

1636-712000b5-19d7-45cb-aea0-b9d9c441c3bd.PDF.....1-7

1636-8b01462d-816b-4a1c-90fc-0844839c2131.PDF.....8-25

1636-2094e9d6-026e-4bdf-a0c3-5a73c328e427.PDF.....26-29

FERC GENERATED TARIFF FILING.RTF.....30-46